

# Contents

## HP E1343A/44A/45A/47A Relay Multiplexer User's Manual

Edition 5

---

Warranty .....	5
Safety Symbols .....	6
WARNINGS .....	6
Declaration of Conformity .....	7
Reader Comment Sheet .....	9
<b>Chapter 1</b>	
<b>Getting Started .....</b>	<b>11</b>
Using This Chapter .....	11
Multiplexer Module Description .....	11
General Description .....	11
Multiplexer Channel Descriptions and Connections .....	11
Programming the Multiplexer Module .....	14
Selecting Channels .....	14
SCPI Command Format Used in This Manual .....	16
Initial Operation .....	17
<b>Chapter 2</b>	
<b>Configuring the Relay Multiplexer Modules .....</b>	<b>19</b>
Warnings and Cautions .....	19
Connecting Field Wiring .....	20
Wiring Guidelines .....	20
Wiring a Terminal Module .....	21
Connecting the Analog Bus .....	22
Setting the Card ID .....	23
Setting the Logical Address Switch .....	23
Using the Multiplexer Module with an HP Mainframe or Command Module .....	24
Using the Scanning Voltmeter Configuration .....	24
Using the Switchbox Configuration .....	25
Verifying Correct Logical Address Settings .....	25
Selecting the Interrupt Priority .....	26
5 Volt Excitation for Strain Gages .....	27
Adding Signal Conditioning Components/Current Shunts .....	27
Connecting User Inputs .....	29
<b>Chapter 3</b>	
<b>Using the Relay Multiplexer Modules .....</b>	<b>31</b>
Using This Chapter .....	31
Multiplexer Commands .....	31
Connecting Switchbox Channels to Common .....	32
Connecting Switchbox Channels to Tree Terminals for Making Measurements .....	34
Scanning a Range of Switchbox Channels .....	36
Measuring Temperature Using Thermocouples (HP E1344A/47A Modules Only) .....	39

<b>Chapter 4</b>	
<b>Understanding the Relay Multiplexer Modules .....</b>	<b>41</b>
Using This Chapter .....	41
Commands for Scanning Switchbox Channels.....	41
Using Scanning Trigger Sources .....	41
Scanning with External Instruments .....	41
Using the Scan Complete Bit.....	46
<b>Chapter 5</b>	
<b>Relay Multiplexer Command Reference .....</b>	<b>47</b>
Using This Chapter .....	47
Command Types .....	47
Common Command Format .....	47
SCPI Command Format .....	47
Linking Commands .....	49
SCPI Command Reference .....	49
ABORT .....	50
ARM .....	51
:COUNT .....	51
:COUNT? .....	52
DISPlay .....	53
:MONitor:CARD .....	53
:MONitor[:STATe] .....	54
INITiate.....	55
:CONTInuous .....	55
:CONTInuous? .....	56
[:IMMediate] .....	56
OUTPut.....	57
[:STATe] .....	57
[:STATe]? .....	57
[ROUTE:].....	58
CLOSE .....	58
CLOSE? .....	59
OPEN .....	59
OPEN? .....	60
SCAN .....	60
SCAN:MODE .....	61
SCAN:MODE? .....	62
SCAN:PORT .....	62
STATus.....	63
:OPERation:ENABLE .....	63
:OPERation[:EVENT]? .....	64
SYSTEM.....	65
:CDEscription? .....	65
:CPON .....	66
:CTYPe? .....	66
:ERRor? .....	67
TRIGger.....	68

[:IMMEDIATE] .....	68
:SOURce .....	69
:SOURce? .....	70
IEEE 488.2 Common Commands.....	71
Command Quick Reference.....	72
<b>Appendix A</b>	
<b>16-Channel Relay Multiplexer Specifications .....</b>	<b>73</b>
HP E1343A/44A 16-Channel Relay Multiplexer .....	73
HP E1345A/47A 16-Channel Relay Multiplexer .....	74
Relay Life .....	75
End of Life Detection .....	75
Replacement Strategy .....	75
<b>Appendix B</b>	
<b>16-Channel Relay Multiplexer Registers .....</b>	<b>77</b>
Register Addressing .....	77
Computer Configurations .....	78
Reading the Registers .....	81
Writing to the Registers .....	82
Register Definitions .....	83
<b>Appendix C</b>	
<b>16-Channel Relay Multiplexer Error Messages .....</b>	<b>85</b>
<b>Index .....</b>	<b>87</b>



---

## Certification

*Hewlett-Packard Company certifies that this product met its published specifications at the time of shipment from the factory. Hewlett-Packard further certifies that its calibration measurements are traceable to the United States National Institute of Standards and Technology (formerly National Bureau of Standards), to the extent allowed by that organization's calibration facility, and to the calibration facilities of other International Standards Organization members.*

---

## Warranty

This Hewlett-Packard product is warranted against defects in materials and workmanship for a period of three years from date of shipment. Duration and conditions of warranty for this product may be superseded when the product is integrated into (becomes a part of) other HP products. During the warranty period, Hewlett-Packard Company will, at its option, either repair or replace products which prove to be defective.

For warranty service or repair, this product must be returned to a service facility designated by Hewlett-Packard (HP). Buyer shall prepay shipping charges to HP and HP shall pay shipping charges to return the product to Buyer. However, Buyer shall pay all shipping charges, duties, and taxes for products returned to HP from another country.

HP warrants that its software and firmware designated by HP for use with a product will execute its programming instructions when properly installed on that product. HP does not warrant that the operation of the product, or software, or firmware will be uninterrupted or error free.

## Limitation Of Warranty

The foregoing warranty shall not apply to defects resulting from improper or inadequate maintenance by Buyer, Buyer-supplied products or interfacing, unauthorized modification or misuse, operation outside of the environmental specifications for the product, or improper site preparation or maintenance.

The design and implementation of any circuit on this product is the sole responsibility of the Buyer. HP does not warrant the Buyer's circuitry or malfunctions of HP products that result from the Buyer's circuitry. In addition, HP does not warrant any damage that occurs as a result of the Buyer's circuit or any defects that result from Buyer-supplied products.

NO OTHER WARRANTY IS EXPRESSED OR IMPLIED. HP SPECIFICALLY DISCLAIMS THE IMPLIED WARRANTIES OF MERCHANTABILITY AND FITNESS FOR A PARTICULAR PURPOSE.

## Exclusive Remedies

THE REMEDIES PROVIDED HEREIN ARE BUYER'S SOLE AND EXCLUSIVE REMEDIES. HP SHALL NOT BE LIABLE FOR ANY DIRECT, INDIRECT, SPECIAL, INCIDENTAL, OR CONSEQUENTIAL DAMAGES, WHETHER BASED ON CONTRACT, TORT, OR ANY OTHER LEGAL THEORY.

---

## Notice

The information contained in this document is subject to change without notice. HEWLETT-PACKARD (HP) MAKES NO WARRANTY OF ANY KIND WITH REGARD TO THIS MATERIAL, INCLUDING, BUT NOT LIMITED TO, THE IMPLIED WARRANTIES OF MERCHANTABILITY AND FITNESS FOR A PARTICULAR PURPOSE. HP shall not be liable for errors contained herein or for incidental or consequential damages in connection with the furnishing, performance or use of this material. This document contains proprietary information which is protected by copyright. All rights are reserved. No part of this document may be photocopied, reproduced, or translated to another language without the prior written consent of Hewlett-Packard Company. HP assumes no responsibility for the use or reliability of its software on equipment that is not furnished by HP.

---

## U.S. Government Restricted Rights

The Software and Documentation have been developed entirely at private expense. They are delivered and licensed as "commercial computer software" as defined in DFARS 252.227-7013 (Oct 1988), DFARS 252.211-7015 (May 1991) or DFARS 252.227-7014 (Jun 1995), as a "commercial item" as defined in FAR 2.101(a), or as "Restricted computer software" as defined in FAR 52.227-19 (Jun 1987)(or any equivalent agency regulation or contract clause), whichever is applicable. You have only those rights provided for such Software and Documentation by the applicable FAR or DFARS clause or the HP standard software agreement for the product involved.

---

---



HP E1343A/44A/45A/47A User's Manual  
Edition 5

Copyright © 1997 Hewlett-Packard Company. All Rights Reserved.

---

---

## Documentation History

All Editions and Updates of this manual and their creation date are listed below. The first Edition of the manual is Edition 1. The Edition number increments by 1 whenever the manual is revised. Updates, which are issued between Editions, contain replacement pages to correct or add additional information to the current Edition of the manual. Whenever a new Edition is created, it will contain all of the Update information for the previous Edition. Each new Edition or Update also includes a revised copy of this documentation history page.

Edition 1	September 1989
Update 1	September 1990
Edition 2	July 1992
Edition 3	April 1993
Edition 4	May 1995
Edition 5	April 1997

---

## Safety Symbols



Instruction manual symbol affixed to product. Indicates that the user must refer to the manual for specific **WARNING** or **CAUTION** information to avoid personal injury or damage to the product.



Alternating current (AC)



Direct current (DC).



Indicates hazardous voltages.



Indicates the field wiring terminal that must be connected to earth ground before operating the equipment—protects against electrical shock in case of fault.

**WARNING**

Calls attention to a procedure, practice, or condition that could cause bodily injury or death.

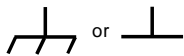

Frame or chassis ground terminal—typically connects to the equipment's metal frame.

**CAUTION**

Calls attention to a procedure, practice, or condition that could possibly cause damage to equipment or permanent loss of data.

---

## WARNINGS

The following general safety precautions must be observed during all phases of operation, service, and repair of this product. Failure to comply with these precautions or with specific warnings elsewhere in this manual violates safety standards of design, manufacture, and intended use of the product. Hewlett-Packard Company assumes no liability for the customer's failure to comply with these requirements.

**Ground the equipment:** For Safety Class 1 equipment (equipment having a protective earth terminal), an uninterruptible safety earth ground must be provided from the mains power source to the product input wiring terminals or supplied power cable.

DO NOT operate the product in an explosive atmosphere or in the presence of flammable gases or fumes.

For continued protection against fire, replace the line fuse(s) only with fuse(s) of the same voltage and current rating and type. DO NOT use repaired fuses or short-circuited fuse holders.

**Keep away from live circuits:** Operating personnel must not remove equipment covers or shields. Procedures involving the removal of covers or shields are for use by service-trained personnel only. Under certain conditions, dangerous voltages may exist even with the equipment switched off. To avoid dangerous electrical shock, DO NOT perform procedures involving cover or shield removal unless you are qualified to do so.

**DO NOT operate damaged equipment:** Whenever it is possible that the safety protection features built into this product have been impaired, either through physical damage, excessive moisture, or any other reason, REMOVE POWER and do not use the product until safe operation can be verified by service-trained personnel. If necessary, return the product to a Hewlett-Packard Sales and Service Office for service and repair to ensure that safety features are maintained.

**DO NOT service or adjust alone:** Do not attempt internal service or adjustment unless another person, capable of rendering first aid and resuscitation, is present.

**DO NOT substitute parts or modify equipment:** Because of the danger of introducing additional hazards, do not install substitute parts or perform any unauthorized modification to the product. Return the product to a Hewlett-Packard Sales and Service Office for service and repair to ensure that safety features are maintained.

**Declaration of Conformity**  
**according to ISO/IEC Guide 22 and EN 45014**

**Manufacturer's Name:** Hewlett-Packard Company  
Loveland Manufacturing Center

**Manufacturer's Address:** 815 14th Street S.W.  
Loveland, Colorado 80537

declares, that the product:

**Product Name:** 16-Channel Relay Multiplexer Modules

**Model Number:** HP E1343A/44A/45A/47A

**Product Options:** All

conforms to the following Product Specifications:

**Safety:** IEC 348:1978/HD 401 S1:1981  
CSA 556B  
UL 1244

**EMC:** CISPR 11:1990/EN55011 (1991): Group 1 Class A  
EN50082-1:1992  
IEC 801-2:1991: 4kVCD, 8kVAD  
IEC 801-3:1984: 3 V/m  
IEC 801-4:1988: 1kV Power Line, 0.5kV Signal Lines

**Supplementary Information:** The product herewith complies with the requirements of the Low Voltage Directive 73/23/EEC and the EMC Directive 89/336/EEC (inclusive 89/336/EEC) and carries the "CE" marking accordingly.

Tested in a typical configuration in an HP B-Size VXI mainframe.

Safety qualification performed May, 1989.

September 5, 1996

  
\_\_\_\_\_  
Jim White, QA Manager

European contact: Your local Hewlett-Packard Sales and Service Office or Hewlett-Packard GmbH, Department HQ-TRE, Herrenberger Straße 130, D-71034 Böblingen, Germany (FAX +49-7031-14-3143)

*Notes:*

---



Please fold and tape for mailing

**Reader Comment Sheet**  
HP E1343A/44A/45A/47A User's Manual  
Edition 5

You can help us improve our manuals by sharing your comments and suggestions. **In appreciation of your time, we will enter you in a quarterly drawing for a Hewlett-Packard Palmtop Personal Computer** (U.S. government employees are not eligible for the drawing).

_____ Your Name	_____ City, State/Province
_____ Company Name	_____ Country
_____ Job Title	_____ Zip/Postal Code
_____ Address	_____ Telephone Number with Area Code

Please list the system controller, operating system, programming language, and plug-in modules you are using.

\_\_\_\_\_  
\_\_\_\_\_  
\_\_\_\_\_

fold here



NO POSTAGE  
NECESSARY  
IF MAILED  
IN THE  
UNITED STATES



POSTAGE WILL BE PAID BY ADDRESSEE

**HEWLETT-PACKARD COMPANY**

Measurement Systems Division  
Learning Products Department  
P.O. Box 301  
Loveland, CO 80539-9984

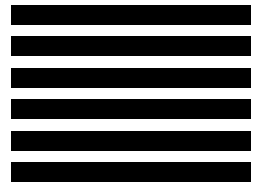

cut along this line



fold here

Please pencil-in one circle for each statement below:

- The documentation is well organized.
- Instructions are easy to understand.
- The documentation is clearly written.
- Examples are clear and useful.
- Illustrations are clear and helpful.
- The documentation meets my overall expectations.

Disagree ←————→ Agree

<input type="radio"/>	<input type="radio"/>	<input type="radio"/>	<input type="radio"/>	<input type="radio"/>
<input type="radio"/>	<input type="radio"/>	<input type="radio"/>	<input type="radio"/>	<input type="radio"/>
<input type="radio"/>	<input type="radio"/>	<input type="radio"/>	<input type="radio"/>	<input type="radio"/>
<input type="radio"/>	<input type="radio"/>	<input type="radio"/>	<input type="radio"/>	<input type="radio"/>
<input type="radio"/>	<input type="radio"/>	<input type="radio"/>	<input type="radio"/>	<input type="radio"/>
<input type="radio"/>	<input type="radio"/>	<input type="radio"/>	<input type="radio"/>	<input type="radio"/>

Please write any comments or suggestions below—be specific.

\_\_\_\_\_  
\_\_\_\_\_  
\_\_\_\_\_  
\_\_\_\_\_  
\_\_\_\_\_  
\_\_\_\_\_  
\_\_\_\_\_  
\_\_\_\_\_



### Using This Chapter

This chapter describes the HP E1343A 16-Channel High Voltage Relay, E1344A 16-Channel General Purpose Thermocouple High Voltage Relay, E1345A 16-Channel Relay, and HP E1347A 16-Channel Thermocouple Relay Multiplexer Modules, and shows how to program the modules using SCPI commands (Standard Commands for Programmable Instruments). This chapter contains the following sections:

- [Multiplexer Module Description](#) . . . . . page 11
- [Programming the Multiplexer Module](#) . . . . . page 14
- [Initial Operation](#) . . . . . page 17

### Multiplexer Module Description

Refer to [Figure 1-1](#) for the following explanations of all four 16-Channel Relay Multiplexer Modules.

#### General Description

The multiplexer module switches (multiplexes) up to 16 channels. Each channel provides High (H), Low (L), and Guard (G) connections.

The multiplexer module consists of a component assembly and a terminal module. The channel relay switches are on the component assembly. The field wiring from user sources (e.g., thermocouples) connects to the terminal module. The terminal module also provides connections for multimeters, voltmeters, counters, and other measuring devices.

#### Multiplexer Channel Descriptions and Connections

The channel relay switches are separated into two banks, Bank 0 and Bank 1. Channels 00 to 07 are in Bank 0 and channels 08 to 15 are in Bank 1. Each bank has its own H, L, and G Common terminals to which the channel switches connect.

The channel switches also connect, through the AT and BT Tree Switches, to the AT and BT Tree Switch Terminals, respectively. The Bank 0 channels connect to the AT Tree Switch Terminals and the Bank 1 channels connect to the BT Tree Switch Terminals. An additional tree switch, the AT2 Tree Switch, provides connection of the Bank 1 channels to AT Tree Switch Terminals. Use channel numbers 90, 91, and 92 to select the AT, BT, and AT2 Tree Switches, respectively.

Connecting to the Tree Switch Terminals is the preferred method to connect measuring devices, like multimeters, to measure the multiplexer channels. This allows you to connect the measuring device to either the Bank 0 or Bank 1 channels at any given time, or to the channels of both banks.

The AT Tree Switch Terminals also connect to the H, L, and G connections on the Analog Bus Connector. The BT Tree Switch Terminals also connect to the I+, I-, and IG connections on the Analog Bus Connector. The Analog Bus Connector provides direct channel connections between multiple multiplexer modules, and connections between a multiplexer module and the HP E1326/E1411 Multimeters. Cables make the necessary connections without the need to externally wire the multimeter/multiplexer modules via the terminal modules.

The 16-Channel Thermocouple Relay Multiplexer Modules (HP E1344A and E1347A) uses the RT Tree Switch (Channel 93) to connect the thermistor on the terminal module to the Bank 1 channel common. The thermistor can be measured to determine the temperature inside of the terminal module to compensate for temperature measurements made with thermocouples (see Chapter 3).

Each channel High (H) line has a jumper on the terminal module that may be removed to add filter components (see Chapter 2 under the “Adding Signal Conditioning Components/Current Shunts” heading). Each Bank 0 and Bank 1 common line, the AT and BT Tree Switch, and the Analog Bus lines all have 100 ohm resistors in series with each line. The resistors provide relay protection and are located on the component module.

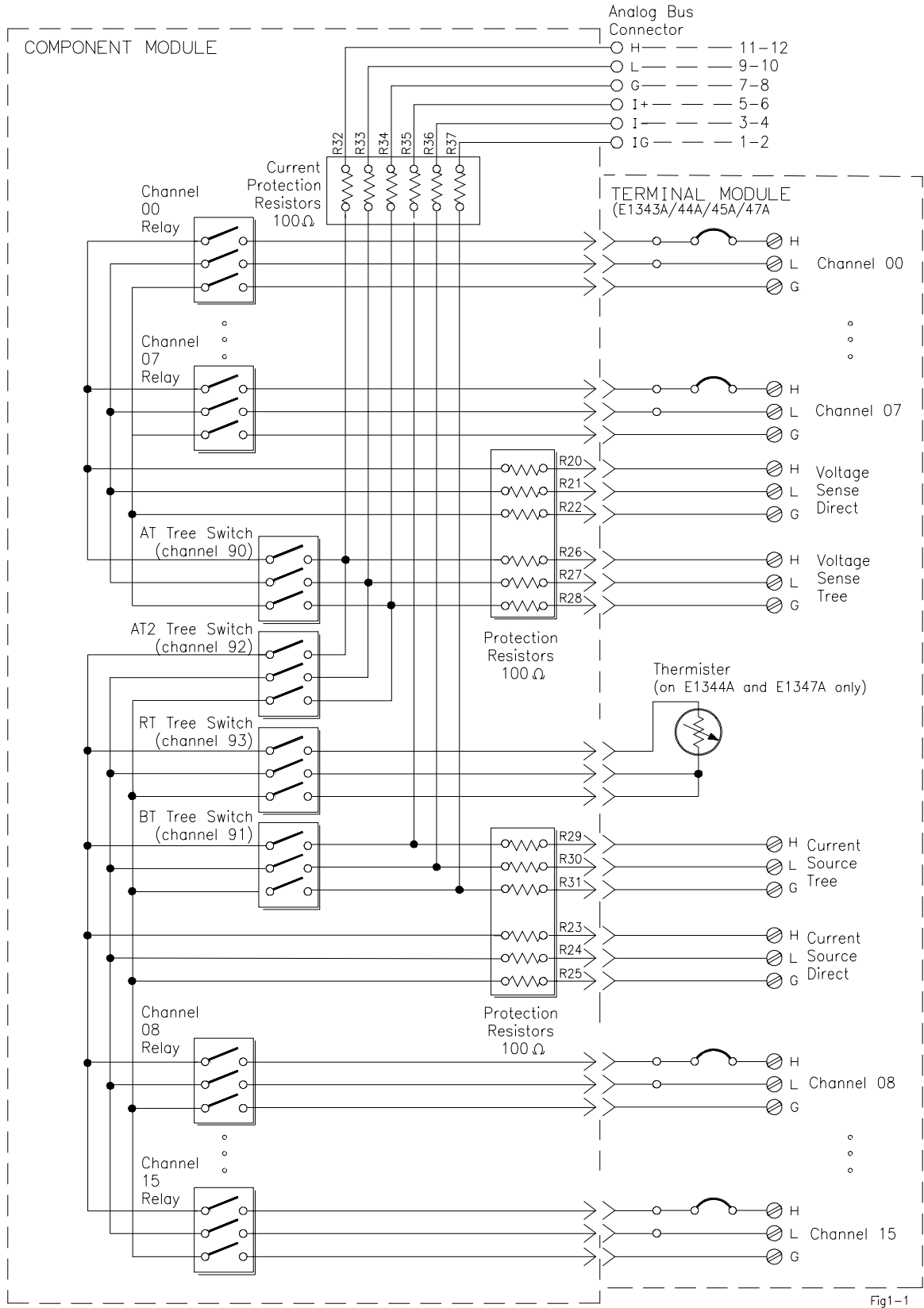

Fig1-1

Figure 1-1. Multiplexer Module Block Diagram

# Programming the Multiplexer Module

The multiplexer modules are programmed either in a switchbox or scanning voltmeter configuration. To program the multiplexer modules using the Standard Commands for Programmable Instruments (SCPI), you must select the controller language, interface address, and SCPI commands to be used. See the *HP 75000 Series B Installation and Getting Started Guide* or the *HP E1406 Command Module Manual* for interface addressing and controller language information of multiplexer modules in a switchbox or scanning voltmeter configuration. **If using the HP E1300 Mainframe or HP E1405 Command Module, you MUST have version 06.00 (or greater) firmware for the Multiplexer Modules to properly identify.**

---

**Note** This discussion applies to SCPI programming. See Appendix B (“16-Channel Relay Multiplexer Registers”) for details on multiplexer modules registers.

---

## Selecting Channels

To address specific channels within a multiplexer module in a switchbox or scanning voltmeter configuration, you must:

- send the appropriate SCPI command string to the switchbox or scanning voltmeter (e.g., CLOSe, OPEN, etc.)
- specify the card number
- specify the channel number

### Multiplexer Card Numbers

The card number identifies the module within a switchbox or scanning voltmeter configuration. The switch module with the lowest logical address is always card number 01. The card number with the next successive logical address is 02, and so on. [Figure 1-2](#) illustrates the card number and logical address of a typical single module switchbox.

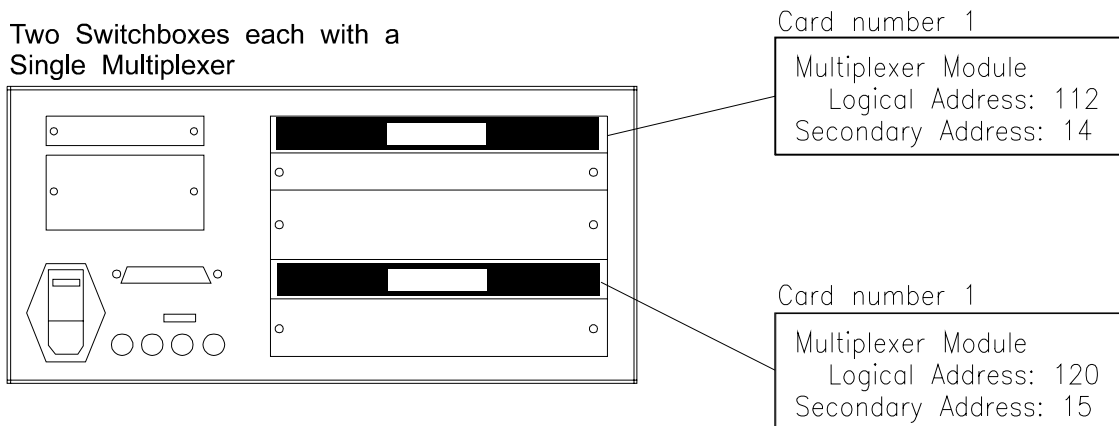

E1345 Fig1-2

**Figure 1-2. Card Numbers for a Single Module Switchbox**

Figure 1-3 illustrates the card numbers and logical addresses of a typical multiple module switchbox. Figure 1-4 illustrates the card numbers of a typical multiple module scanning voltmeter.

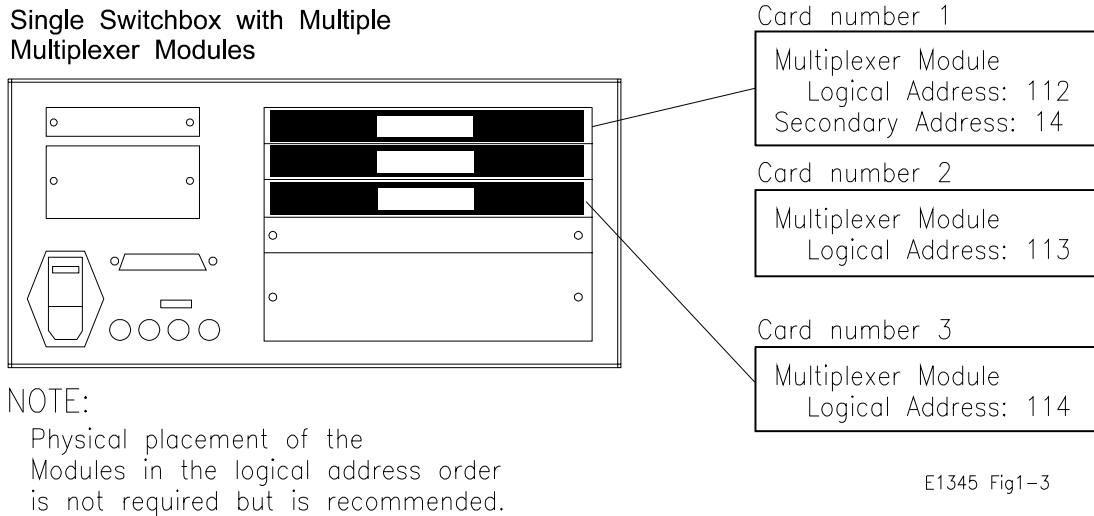

**Figure 1-3. Card Numbers for a Multiple Module Switchbox**

The logical addresses noted in Figures 1-2, 1-3, and 1-4 apply to modules installed in an HP 75000 Series B Mainframe (HP Model Number E1300/E1301) or in a mainframe with an HP E1405/E1406 Command Module. See the *HP 75000 Series B Installation and Getting Started Guide* or the *HP E1406 Command Module Manual* for more information on switchboxes and scanning voltmeter configurations, and logical addressing. **If using the HP E1300 Mainframe or HP E1405 Command Module, you MUST have version 06.00 (or greater) firmware for the 16-Channel Multiplexer Modules to properly identify.** For uses in other systems or mainframes, see the appropriate manuals.

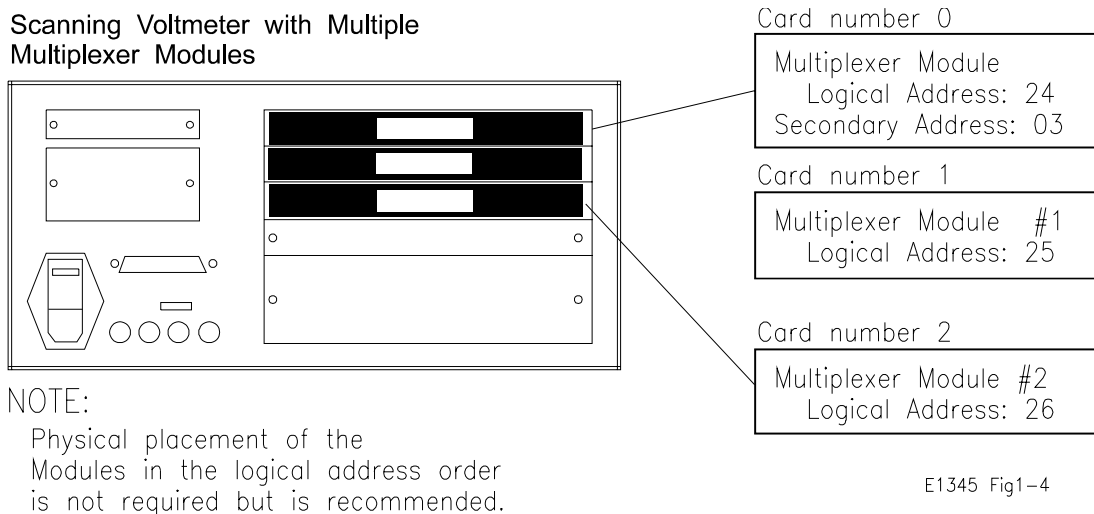

**Figure 1-4. Card Numbers for a Multiple Module Scanning Voltmeter**

## Multiplexer Channel Address

For the 16-Channel Multiplexers, the channel address (*channel\_list*) is in the form:

- (@ccnn) for a single channel;
- (@ccnn,ccnn) for multiple channels;
- (@ccnn:ccnn) for sequential channels;
- (@ccnn:ccnn,ccnn:ccnn) for groups of sequential channels;
- or any combination of the above.

where "cc" is the card number and "nn" is the channel number.

For example, the command string to close channel 02 of card number 1 is:

```
CLOSE (@0102)
```

Since "cc" (the card number) must be sent, it becomes part of the channel number. Also, you can ignore leading zeros in the card numbers. Thus, to close channel 02, send "102" instead of "0102". To close the above channel, execute:

```
CLOSE (@102)
```

## SCPI Command Format Used in This Manual

You can send SCPI commands in either a short or long form. A long form example is:

```
CLOSE (@102)
```

The same command shown without the lower case letters is the short form. The command then becomes:

```
CLOS (@102)
```

Some commands in this manual are shown with brackets ([ ]). These are implied or optional commands that you do not have to execute. For example, the ROUT command is an implied command and is shown in this manual as:

```
[ROUT:]CLOS (@102)
```

Thus, to execute these commands, simply enter:

```
CLOS (@102)
```

See Chapter 5 for more explanation about SCPI commands and how to send them.



# Initial Operation

Use the following program example to verify initial multiplexer operation by closing a channel and querying channel closure. The example first resets the switchbox and then closes channel 02 of a single multiplexer module (card number 1) in the switchbox. The program next queries the channel closure state. A returned "1" shows that the command to close the channel has been sent to the switchbox. A returned "0" shows that the command to close the channel has not been sent to the switchbox.

The computer used in the example is an HP Series 200/300 computer with HP BASIC as the program language. The computer interfaces to the mainframe using the Hewlett-Packard Interface Bus (HP-IB)<sup>1</sup>. The HP-IB interface select code is 7, the HP-IB primary address is 09, and the HP-IB secondary address is 14. Refer to the *HP 75000 Series B Installation and Getting Started Guide* for addressing information.

### Example: Reset the switchbox and close channel 02

10 OUTPUT 70914;"*RST"	<i>Opens all channels.</i>
20 OUTPUT 70914;"CLOS (@102)"	<i>Close channel 02.</i>
30 OUTPUT 70914;"CLOS? (@102)"	<i>Query channel 02 state.</i>
40 ENTER 70914;Value	<i>Enter results into Value.</i>
50 PRINT Value	<i>Display result.</i>
60 END	

---

1. HP-IB is Hewlett-Packard's implementation of IEEE Std 488.1-1984

*Notes:*

---

# Configuring the Relay Multiplexer Modules

---

This chapter shows how to connect external wiring to the 16-Channel Relay Multiplexer Modules, and how to configure them:

- [Warnings and Cautions](#) . . . . . page 19
- [Connecting Field Wiring](#) . . . . . page 20
- [Wiring a Terminal Module](#) . . . . . page 21
- [Connecting the Analog Bus](#) . . . . . page 22
- [Setting the Card ID](#) . . . . . page 23
- [Setting the Logical Address Switch](#) . . . . . page 23
- [Using the Multiplexer Module with an HP Mainframe or Command Module](#) . . . . . page 24
- [Selecting the Interrupt Priority](#) . . . . . page 26
- [5 Volt Excitation for Strain Gages](#) . . . . . page 27
- [Adding Signal Conditioning Components/Current Shunts](#) . . . . . page 27
- [Connecting User Inputs](#) . . . . . page 29

## Warnings and Cautions

---

**WARNING** **SHOCK HAZARD.** Only service-trained personnel who are aware of the hazards involved should install, remove, or configure the modules. Before installing any module, disconnect AC power from the mainframe and from user wiring.

To prevent electrical shock, all wires to the channel connections must be insulated to at least 120 Vrms (170 V peak).

---



---

**Caution** **MAXIMUM VOLTAGE/CURRENT.** Maximum voltage that may be applied between High (H), Low (L), and Guard (G) terminals is 170 V dc or 120 V rms (170 V peak) for the E1345A/47A or 250 V dc or AC RMS (354 V peak) for the E1343A/44A. Maximum current is 50mA (non-conductive) per channel.

**STATIC ELECTRICITY.** Static electricity is a major cause of component failure. To prevent damage to the electrical components in the multiplexer module, observe anti-static techniques whenever removing a module from the mainframe or whenever working on a module.

---

# Connecting Field Wiring

Figure 2-1 shows the terminal module for the 16-Channel High Voltage Relay (HP E1343A), 16-Channel Relay (HP E1345A), 16-Channel General Purpose Thermocouple High Voltage Relay (HP E1344A), and 16-Channel Thermocouple Relay Multiplexer Modules (HP E1347A). Use the following guidelines for wire connections.

## Wiring Guidelines

- If possible, use shielded cables with the shields connected to the Guard (G) terminals and to the low connection near the measurement point.
- Be sure the wires make good connections on the screw terminals.
- For thermocouples, connect the Guard terminal to the thermocouple's shield lead and the low connection near the measurement point.

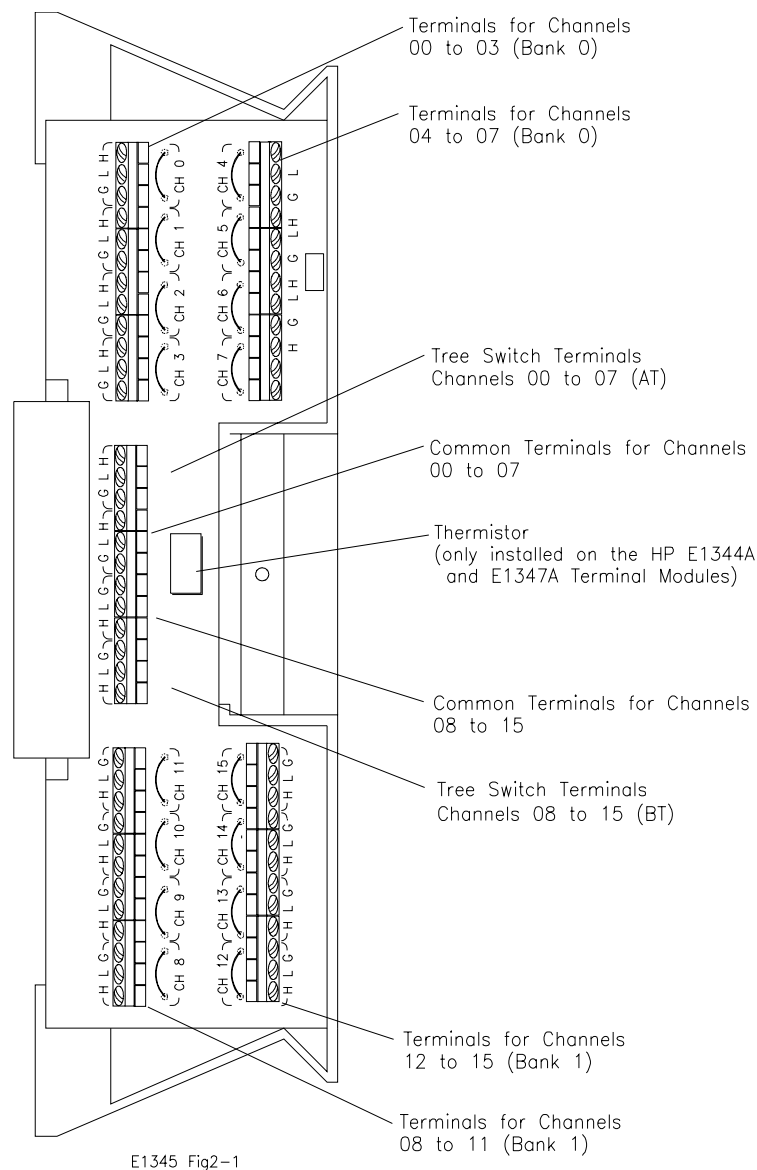

**Figure 2-1. Multiplexer Modules Connector Blocks**

# Wiring a Terminal Module

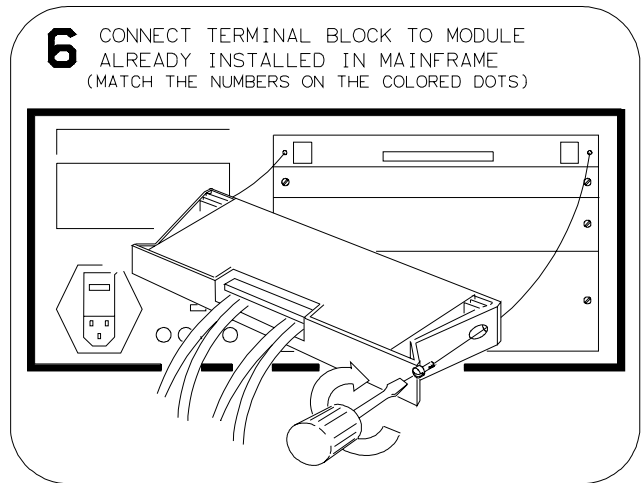
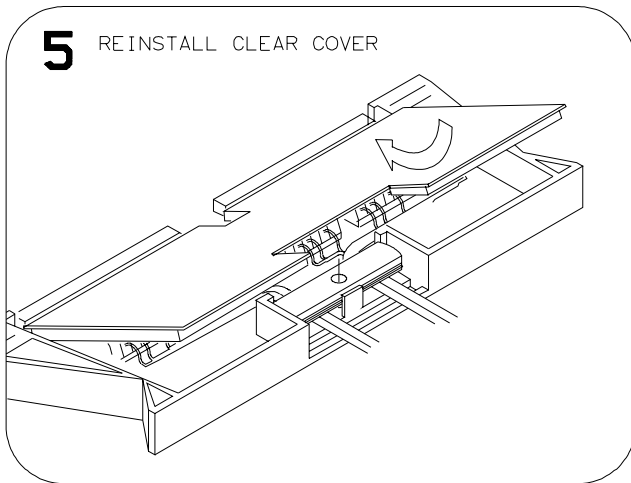
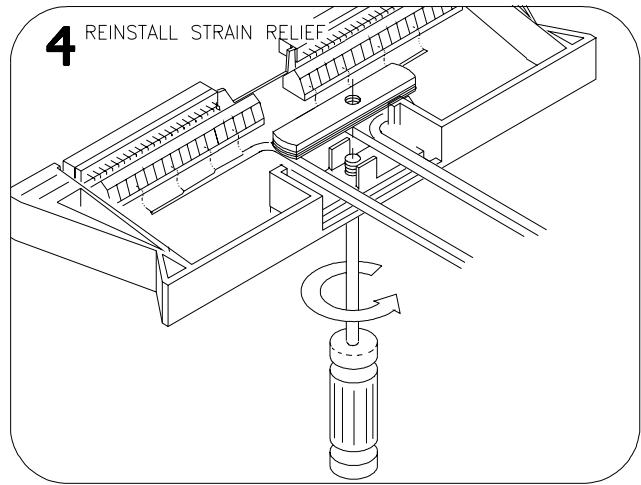
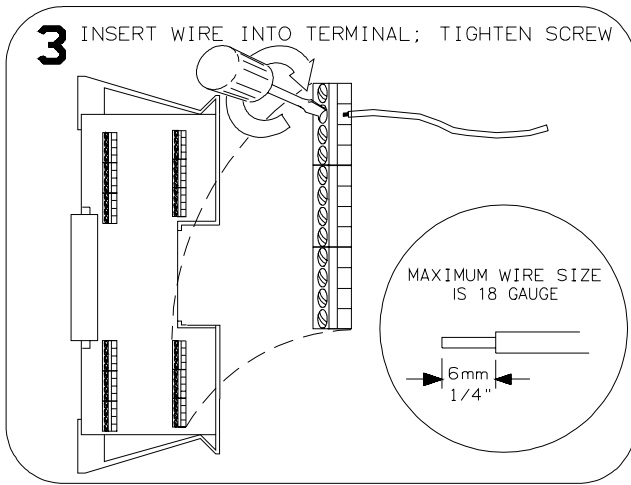
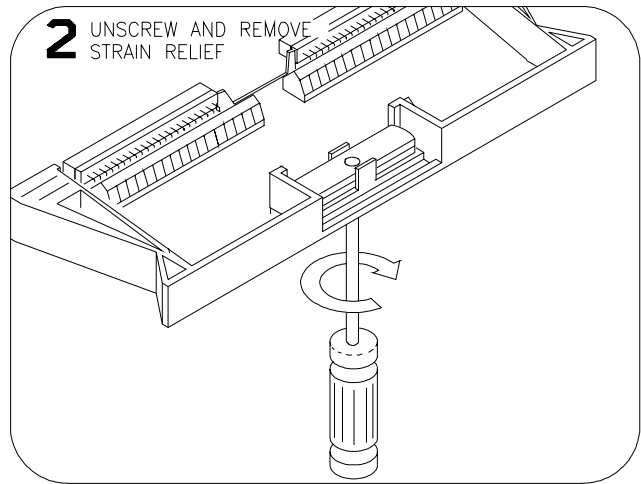
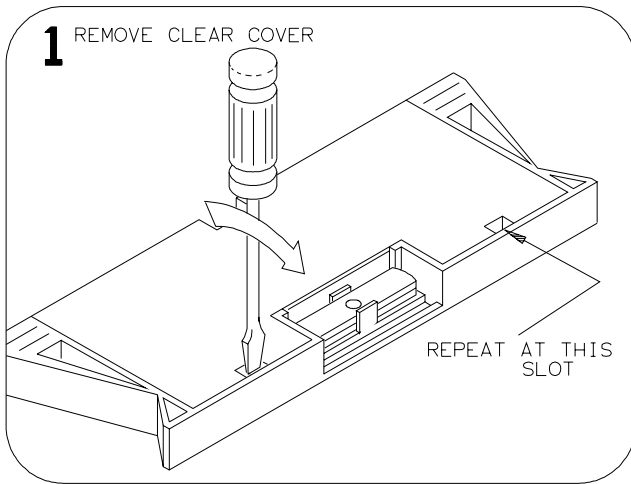

E1345 Fig2x

# Connecting the Analog Bus

Figure 2-2 shows how to connect the analog bus between multiple multiplexer modules and to the HP E1326 Multimeter. Use the cables shipped with the multiplexer modules to connect the analog bus of the multiplexer modules. Use the cable shipped with the HP E1326 Multimeter to connect the analog bus of the multiplexer module to the Multimeter input.

These cables are needed to connect the MUX when mounted in the E1403 Module Carrier to the E1411A/B DMM in a C-size cardcage. They must be ordered separately.

1. Connecting E1411 to RELAY MUXs: use E1326-61611 (long analog bus cable).
2. Connecting RELAY to RELAY or RELAY to FET MUX: use E1400-61605.

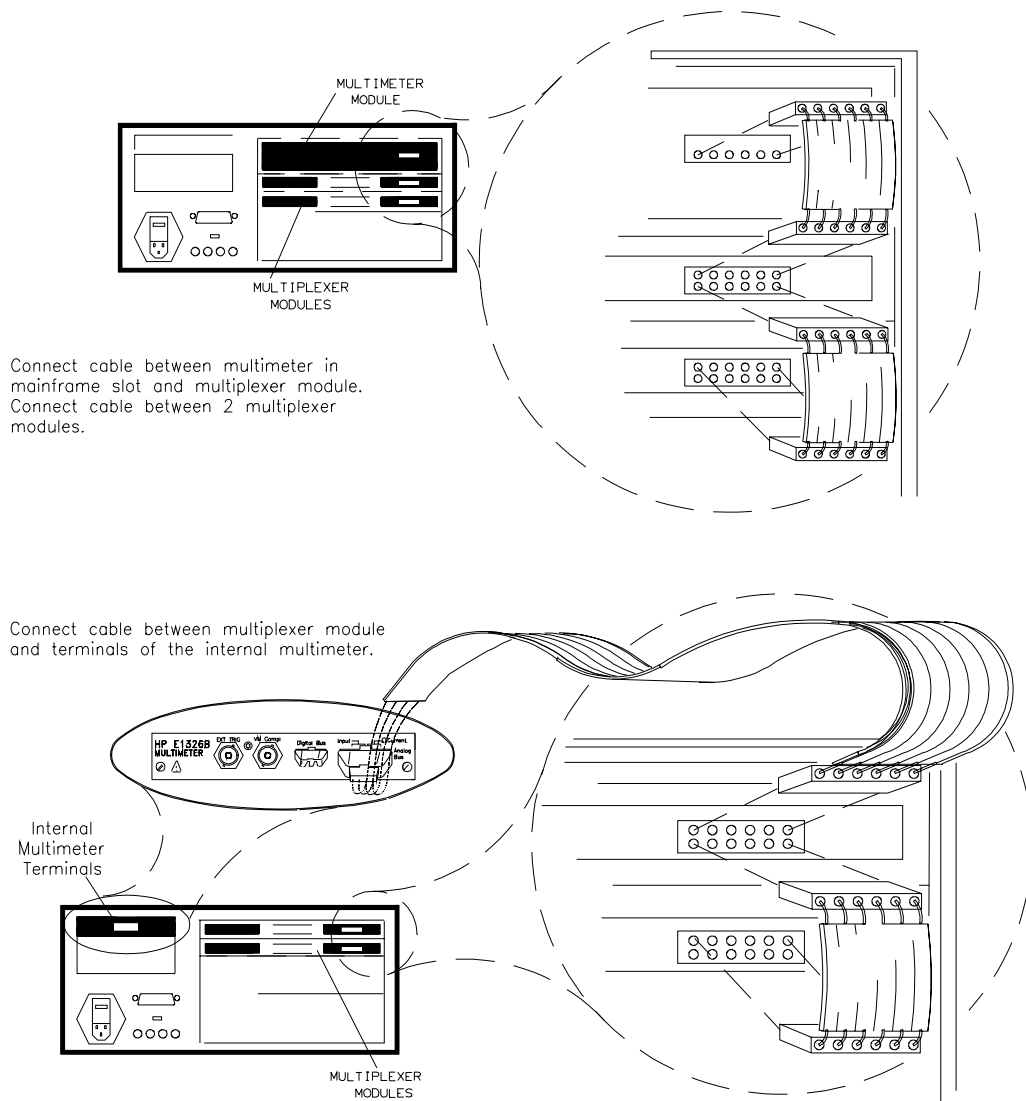

E1345A FIG2-2

Figure 2-2. Analog Bus Connections Between Multiplexer/Multimeter Modules

## Setting the Card ID

The Card ID Jumpers indicate which terminal assembly is used. Since the HP E1343-66201 and E1345-66201 assembly is used with a variety of terminal modules, the ID jumpers may be changed. To reduce setup time and avoid configuration errors, check the jumpers to make sure they match the terminal module used.

When the relay multiplexers are shipped from the factory, the Card ID Jumpers are set according to the terminal module (E1343/44/45/47/55/56) shipped with them. The system is able to identify the multiplexer with or without the terminal module attached.

---

**Note** If the jumper setting does not match the terminal module attached, the system will identify the card based on the jumper setting.

---

## Setting the Logical Address Switch

The address switch (LADDR) factory setting is 112. You may have changed the setting during module installation. Valid address values are from 0 to 255. Refer to the *HP 75000 Series B System Installation and Getting Started Guide* or the *HP E1406 Command Module Manual* for addressing information. Otherwise, to change the setting, refer to the [Figure 2-3](#).

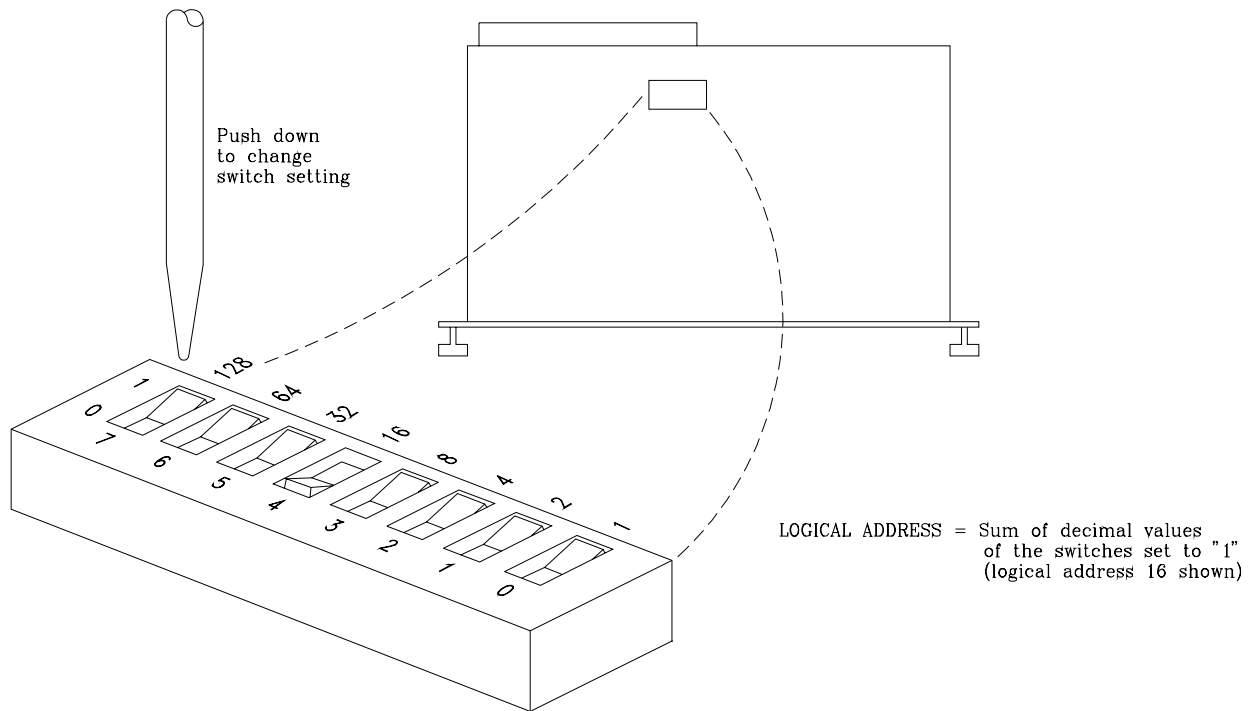

**Figure 2-3. Locate and Set the Logical Address Switch**

# Using the Multiplexer Module with an HP Mainframe or Command Module

To program the multiplexer modules with an HP E1300A/01A Mainframe or an HP E1405B/E1406A Command Module, the modules must be configured as an instrument. **If using the HP E1300 Mainframe or HP E1405 Command Module, you MUST have version 06.00 (or greater) firmware for the 16-Channel Multiplexer Modules to properly identify.** An instrument configuration for the multiplexer modules must be a:

- Scanning Voltmeter - Used with an HP E1326B/E1411A Multimeter.
- Switchbox - Used with other switch type modules, like other multiplexer modules, etc.

(The above requirements are not necessary if using register-based programming to program the modules.)

## Using the Scanning Voltmeter Configuration

Use this configuration for:

1. Easiest system programming.
2. Fastest execution speed.
3. Thermocouple measurements if using the HP E1326B/E1411B temperature function.

To use this configuration, set the multimeter's logical address to a multiple of 8. Also set the first multiplexer module's logical address to the next address value, the second module to the next address value, and so on. The following shows the logical address settings of a Scanning Voltmeter with the multimeter address set to 24.

Logical Address	Module	Channels
24	HP E1326B/E1411A	N/A
25	HP E1345A/E1347A	100-115
26	HP E1345A/E1347A	200-215

To program the scanning voltmeter, use the programming information in the appropriate multimeter manual.



## Using the Switchbox Configuration

Use this configuration when:

1. Simultaneously closing multiple channels on multiple modules.
2. Other multimeters/modules cannot control the multiplexer modules.

To use this configuration, set the first multiplexer module's logical address to a multiple of 8. Set the next multiplexer module's logical address to the next address value, the third module to the next address value, and so on. The following shows the logical address settings of a switchbox with the first multiplexer module address set to 112.

Logical Address	Module	Channels
112	HP E1345A/E1347A	100-115
113	HP E1345A/E1347A	200-215
114	HP E1345A/E1347A	300-315

To program the switchbox, use the programming information in this manual.

## Verifying Correct Logical Address Settings

To verify that the modules have the correct logical address setting, query the HP E1300A/E1301A Mainframe or HP E1405B/E1406A Command Module as follows:

**HP E1301A Mainframe** - From the "Select a Instrument" prompt of the front panel, select the following menus:

```
SYSTEM
CONFIG?
LADDS
```

**HP E1300A Mainframe, HP E1405B, or HP E1406A Command Module with an RS-232 Terminal** - From the "Select an Instrument" prompt, select the following menus:

```
SYSTEM
CONFIG?
LADDS
```

If no front panel or RS-232 terminal is available, send the following SCPI query command to the mainframe/command module:

```
VXI:CONF:DLAD?
```

The returning string contains all logical addresses in the system.

# Selecting the Interrupt Priority

The multiplexer modules generate interrupts after a channel relay closing or opening completes. These interrupts set the selected line on the VXI peripheral interrupt bus true.

The VXI peripheral interrupt bus consists of 7 interrupt priority lines that carry the interrupt signal to the commander. Line 1 has the highest priority and line 7 the lowest. The multiplexer module's default setting is line 1, since it is the most commonly used interrupt line.

The HP E1300A/E1301A Mainframe default operation is to monitor all seven interrupt lines. The HP E1405B/E1406A Command Module's default operation is to manage only one line. The Command Module does, however, use an interrupt line allocation table that allows you to select which lines the command module is to monitor. For embedded controllers, refer to the appropriate controller documentation to determine which of the line(s) the controller monitors.

When using an HP E1300A/E1301A Mainframe or HP E1405B/E1406A Command Module for register-based programming (instead of the SCPI driver) and where the program generates an interrupt, be sure to use the multiplexer module's interrupt line that does not interfere with the program. Use the line that is not used by the SCPI driver to generate interrupts.

Refer to [Figure 2-4](#) to change the interrupt priority. Unsolder and remove two jumpers from the old priority location. Install the jumpers in the new priority location ([Figure 2-4](#) shows a priority change from 1 to 7).

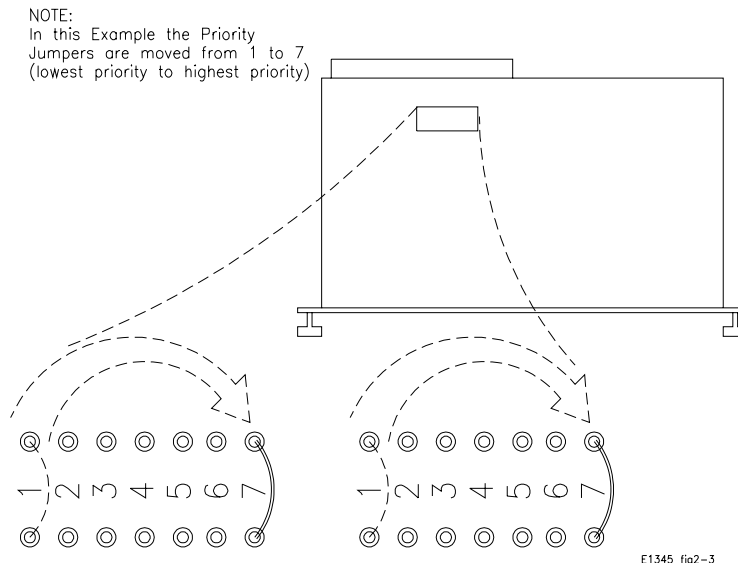

**Figure 2-4. Changing the Priority Interrupt Level Jumpers**

## 5 Volt Excitation for Strain Gages

The E1345-66201 is used with a variety of terminal modules including the E1355A and E1356A Strain Gage Multiplexers. When used with these strain gages, the jumpers JM1 and JM2 may be installed to provide 5 volt excitation to the strain gage bridge. This voltage is fused at 4A. Channel x93 is used to sense it.

Jumpers JM1 and JM2 must be removed when used with the E1347A Thermocouple terminal module. This must be done because the connector pins in this case are used to sense the 5k Ohm thermistor on the terminal module.

When the relay multiplexer is shipped from the factory, the jumpers are not installed.

## Adding Signal Conditioning Components/Current Shunts

The multiplexer module's terminal module allows you to add components on each channel for:

- Low-Pass Filters
- Attenuators
- Current Shunts (for current measurements using a voltmeter)

[Figure 2-5](#) shows how to install the appropriate components for the above configurations. In the figure, channel 12 shows a low pass filter configuration, channel 07 an attenuator configuration, and channel 04 a current shunt configuration.

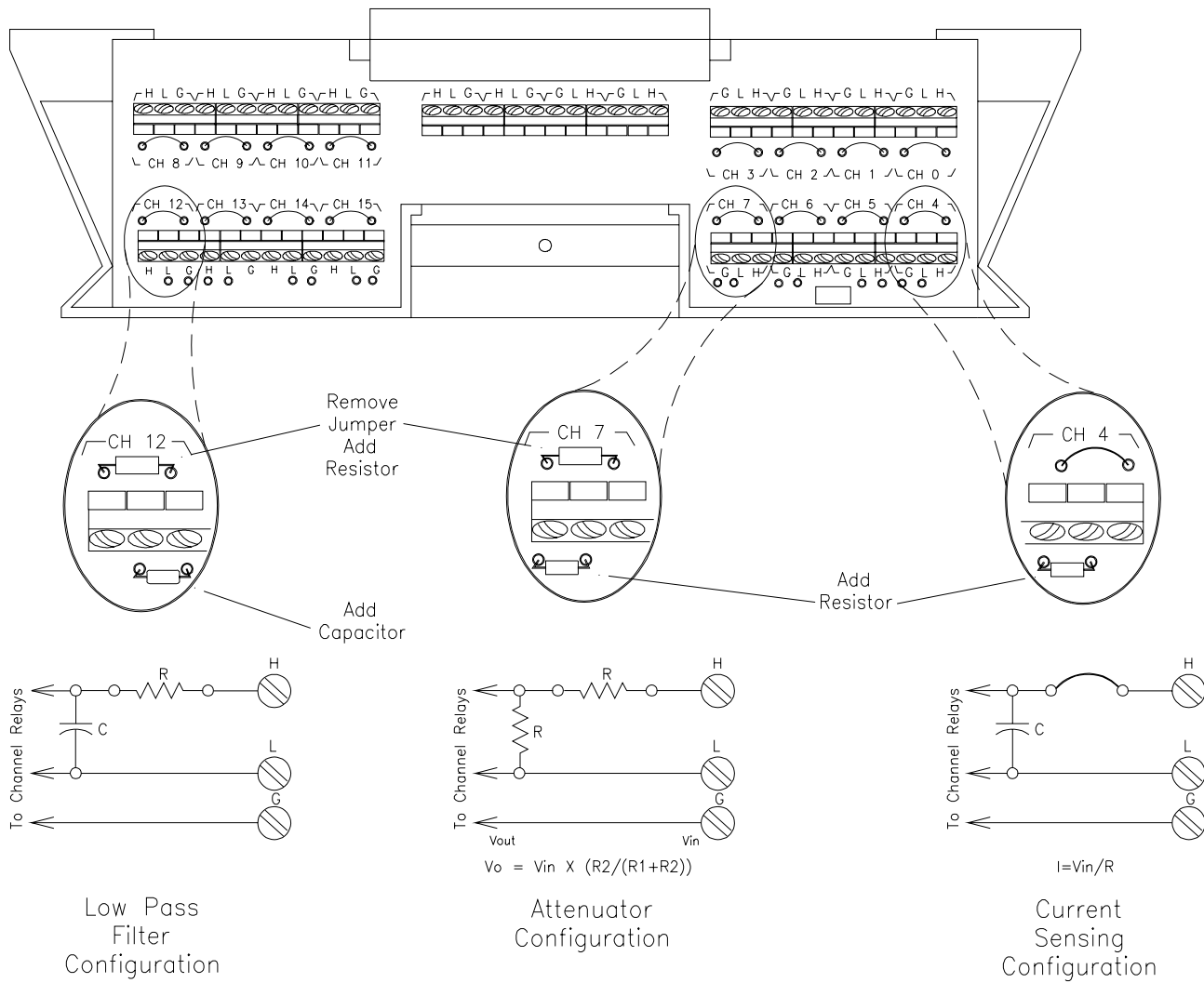

E1345 Fig2-4

**Figure 2-5. Signal Conditioning Components/Current Shunts**

# Connecting User Inputs

The relay switch modules consist of a relay component module and a connector (terminal) block. If you choose not to use the supplied connector block, [Figure 2-6](#) shows the front panel for the modules and the connection diagram for wiring your own terminal connector.

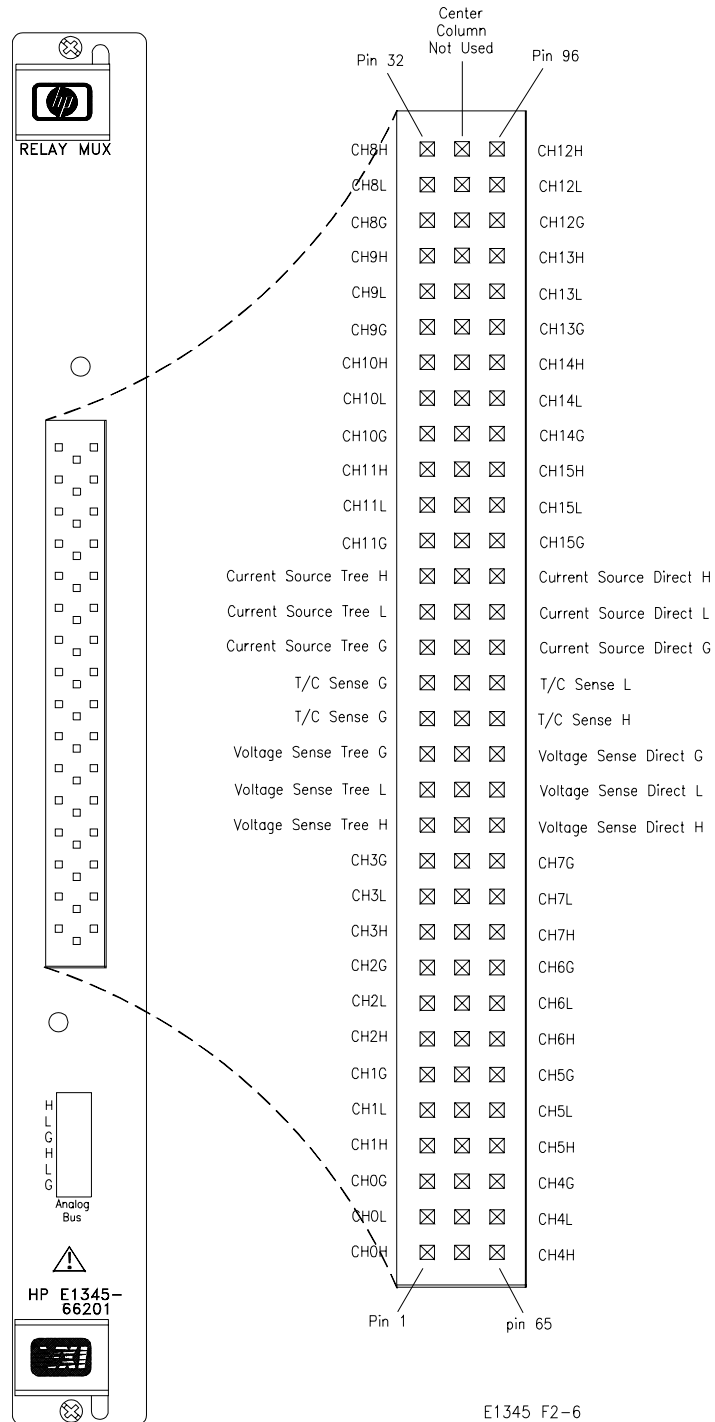

Figure 2-6. Relay Multiplexer Modules Front Panel and Connector Pinout

*Notes:*

---

# Chapter 3

# Using the Relay Multiplexer Modules

---

## Using This Chapter

This chapter uses typical examples to show how to use the 16-Channel Relay and 16-Channel Thermocouple Relay Multiplexer Modules. Refer to Chapter 4 (“Understanding the Relay Multiplexer Modules”) for more information. This chapter contains the following sections:

- [Multiplexer Commands](#) . . . . . page 31
- [Connecting Switchbox Channels to Common](#) . . . . . page 32
- [Connecting Switchbox Channels to Tree Terminals for Making Measurements](#) . . . . . page 34
- [Scanning a Range of Switchbox Channels](#) . . . . . page 36
- [Measuring Temperature Using Thermocouples \(HP E1344A/47A Modules Only\)](#) . . . . . page 39

## Multiplexer Commands

**Table 3-1. Multiplexer Commands in Chapter 3**

Command	Description
ARM:COUN <number>	Selects multiple scanning cycles.
INIT[:IMM]	Starts scanning process; use the [ROUT:]SCAN command to select channels for scanning.
INIT:CONT 1 0 ON OFF	Enables/disables continuous scanning cycles.
[ROUT:]CLOS <channel_list>	Closes all channels in <i>channel list</i> .
[ROUT:]CLOS? <channel_list>	Queries mainframe for channel closure.
[ROUT:]OPEN <channel_list>	Opens all channels in <i>channel list</i> .
[ROUT:]SCAN <channel_list>	Closes all channels in <i>channel list</i> one at a time; previous channel opens before next channel closes.
[ROUT:]SCAN:MODE FRES	Automatically closes paired channel relays (e.g., channels 01 and 09) during 4-wire ohms measurements and scanning.
[ROUT:]SCAN:PORT ABUS	Automatically closes the tree switches while scanning.
NOTE: The commands with brackets ([ ]) are implied and are not shown in this chapter	

# Connecting Switchbox Channels to Common

- Closing any channel in Bank 0 (i.e., channels 00 to 07) connects the channel to the Bank 0 Common.
- Closing any channel in Bank 1 (i.e., channels 08 to 15) connects the channel to the Bank 1 Common.

## Example: Connect Channels 02 and 09 to Common

Figure 3-1 shows how to connect channels 02 and 09 of a single module switchbox to their respective Common Terminals. Execute:

`CLOS (@102,109)`

*102 closes channel 02 and 109 closes channel 09; the first number (1) is the card number.*

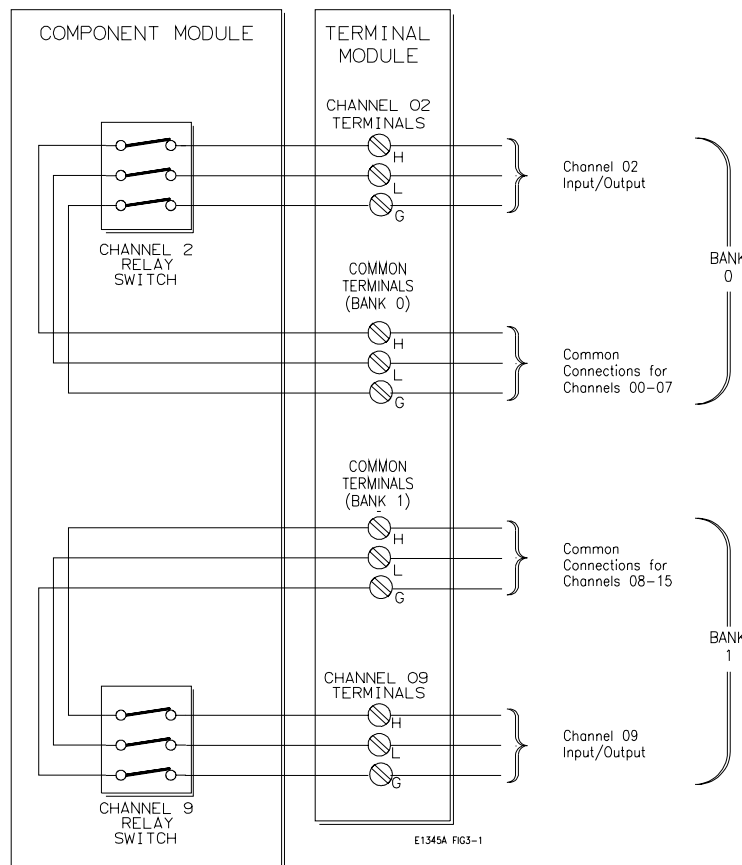

Figure 3-1. Connecting Channels 02 and 09 to their Respective Commons



**Comments** **Opening Channels.** Use the OPEN *<channel\_list>* command to open channels. For example, to open channels 02 and 09, execute:

```
OPEN (@102,109)
```

**Closing/Opening Multiple Channels.** To close or open multiple channels, place a comma (,) between the channel numbers. To close or open a range of channels, place a colon (:) between the channel numbers. You can do this for both single or multiple module switchboxes. For example, to close:

```
-- channels 02 and 04 of a card #1 module, and  
-- channels 07 through 10 of a card #1 module, and  
-- channels 09 and 15 of a card #2 module
```

execute this command:

```
CLOS (@102,104,107:110,209,215)
```

**Closing/Opening Order for Multiple Channels.** Closing/opening order for multiple channels with a single command is not guaranteed.

**Query Open/Closed Channels.** The CLOS? *<channel\_list>* and OPEN? *<channel\_list>* commands determine if the channel in the channel list is open or closed, respectively. (The query command does not determine if, in the event of a hardware failure, the channel remains open/closed.) For example, to determine if the channels in the above example are closed, execute:

```
CLOS? (@102,104,107:110,209,215)
```

and enter the response into a string variable. The returned response should look like: "1,1,1,1,1,1,1,1".

A response of 1 indicates that the channel is closed; a response of 0 indicates that the channel is open. The reverse is true for the OPEN? *<channel\_list>* command. The correct responses for both the OPEN? and CLOS? commands are:

```
CLOS? 1 = Closed  
       0 = Open
```

```
OPEN? 1 = Open  
       0 = Closed
```

---

**Note** You must read the query response after sending a query command or the switchbox will generate an error.

---

# Connecting Switchbox Channels to Tree Terminals for Making Measurements

- Closing the AT Tree Switch connects any channel in Bank 0 (i.e., channels 00 to 07) to the AT Tree Switch Terminals and to the H, L, and G terminals of the Analog Bus connector.
- Closing the BT Tree Switch connects any channel in Bank 1 (i.e., channels 08 to 15) to the BT Tree Switch Terminals and to the I+, I-, and IG terminals of the Analog Bus connector.
- Use the Tree Switch Terminals to connect measuring devices like the HP E1326 Digital Multimeter.

## Example: Connect Channels 02 and 09 to Tree Terminals for Voltage or 2-Wire Ohms Measurements

Figure 3-2 shows how to connect channels 02 and 09 of a single module switchbox to the AT Tree Switch Terminals and the Analog Bus connector for voltage or 2-wire ohms measurements. Execute:

CLOS (@102,190,192)

*102 closes channel 02,  
190 closes the AT tree switch,  
192 closes the AT2 tree switch.*

OPEN (@102)

CLOS (@109)

*Opens channel 02.  
109 closes channel 09.*

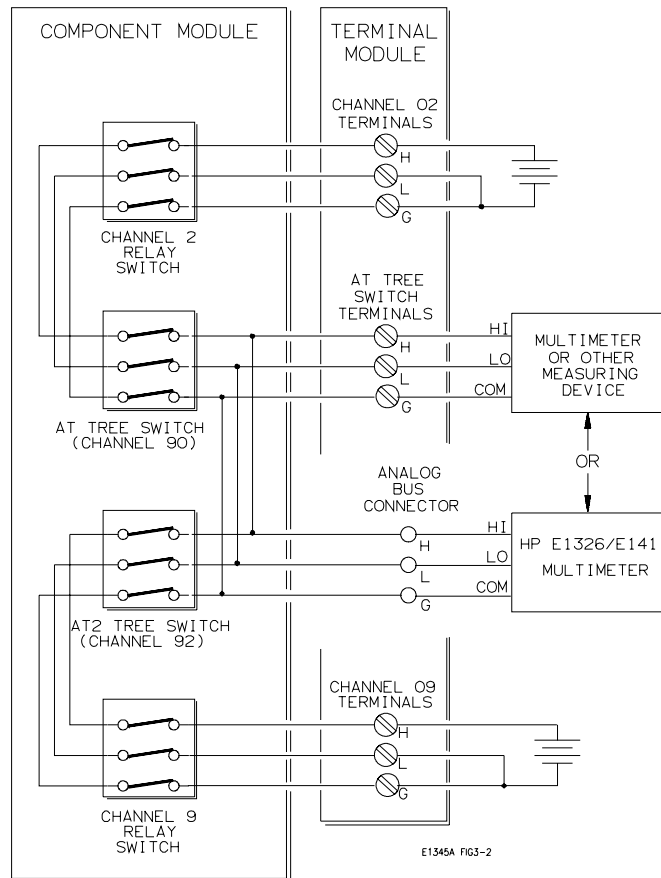

Figure 3-2. Closing Channels 02 and 09 for a Voltage Measurement

**Example: Connect Channels 02 and 10 to Tree Switch Terminals and the Analog Bus for 4-Wire Ohms Measurements**

Figure 3-3 shows how to connect channels 02 and 10 of a single module switchbox to their respective Tree Switch Terminals and the Analog Bus connector for 4-wire ohms measurements. Execute:

CLOS (@102,110,190,191)

*102 closes channel 02,  
110 closes channel 10,  
190 closes the AT tree switch,  
and 191 closes the BT tree switch.*

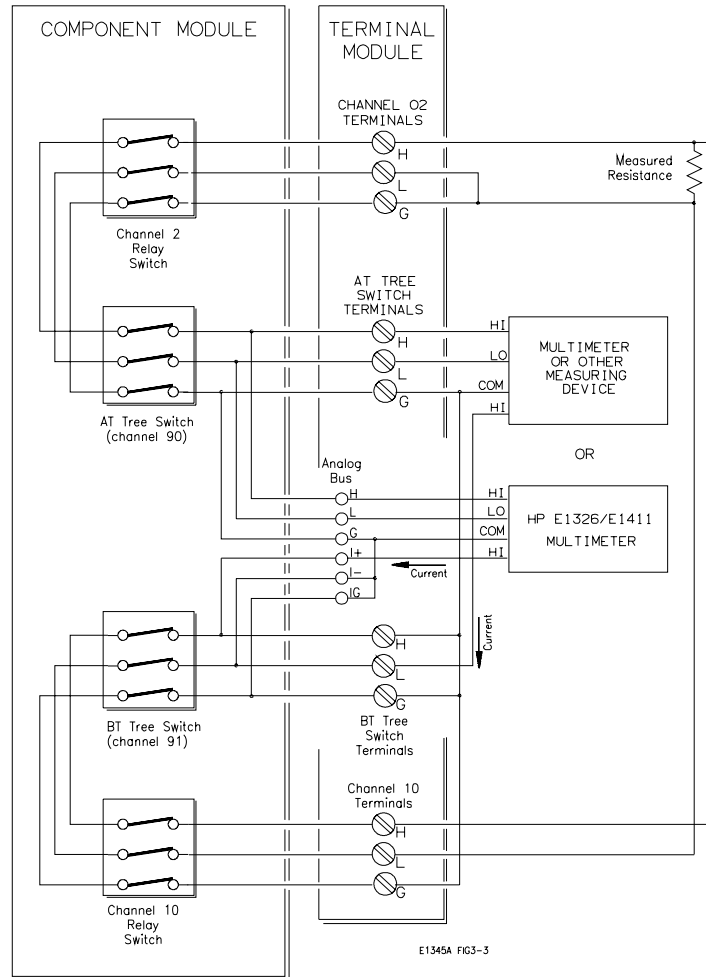

**Figure 3-3. Closing Channels 02 and 10 for a 4-Wire Ohms Measurement**

**Comments** **Opening the AT, BT, and AT2 Tree Switches.** Use the OPEN <channel\_list> command to open the tree switches. For example, to open the AT, BT, and AT2 Tree Switches, execute:

OPEN (@190,191,192)

**Measuring with the HP E1326/E1411 Multimeters.** The HP E1326/E1411 Multimeters can directly measure channels of single or multiple multiplexer modules in a scanning voltmeter configuration. The multimeters, when correctly programmed, automatically close the appropriate AT, BT, and AT2 Tree Switches. For more information, see the *HP E1326/E1411 User's Manual*.

# Scanning a Range of Switchbox Channels

- You can scan a range of channels of a switchbox consisting of single or multiple multiplexer modules (see the “Comments” section for scanning requirements of a switchbox).
- Scanning involves sequentially closing each channel on a range of specified channels.
- During scanning, the relay which was previously closed opens before the next relay closes.

## Example: Making Voltage Measurements by Scanning

Figure 3-4, Figure 3-5, and the following commands, show how to make voltage measurements by performing a single scanning cycle of all channels on two multiplexer modules in a single switchbox. In the example, the:

- AT Tree Switch Terminals of each terminal module connect to each other and to the multimeter in Figure 3-5; to connect the AT Tree Switch Terminals to each other, use either the Analog Bus Cables; Analog Bus (shown in Figure 2-2 on page 22) or wire the terminals together between each terminal modules.
- HP E1300/E1301 Mainframe's "Trig Out" pulse synchronizes the switchbox with the multimeter.
- HP-IB Bus trigger command advances the switchbox channel list.
- Multimeter HP-IB select code is 7 and primary address is 22.
- Switchbox HP-IB select code is 7, the HP-IB primary address is 09, and the HP-IB secondary address is 14.
- Computer is an HP Series 200/300 Computer with HP BASIC using HP-IB.

Enter and Execute:

```
10 OUTPUT 722;"TRIG EXT;DC 10"      !Sets multimeter to external
                                     !triggers and to measure dc volts.
20 OUTPUT 70914;"OUTP ON"           !Enables "Trig Out" port.
30 OUTPUT 70914;"TRIG:SOUR BUS"     !Sets switchbox to receive Bus
                                     !triggers.
40 OUTPUT 70914;"SCAN:MODE VOLT"    !Setup switchbox to measure
                                     !voltage.
50 OUTPUT 70914;"SCAN:PORT ABUS"    !Closes the appropriate Tree
                                     !Switches while scanning;
                                     !automatically makes connection
                                     !to the Analog Bus.
60 OUTPUT 70914;"SCAN (@100:215)"   !Selects channel list. 100 selects
                                     !first channel of module #1;
                                     !215 selects last channel of
                                     !module #2.
70 OUTPUT 70914;"INIT"              !Starts scanning cycle.
80 FOR I=1 TO 32                     !Start count loop.
90 ENTER 722;A                       !Enter reading into variable A.
100 PRINT A                          !Print reading in variable A.
110 TRIGGER 70914                    !Trigger the switchbox to
                                     !advance the scan list.
120 NEXT I                           !Increment count.
130 END
```

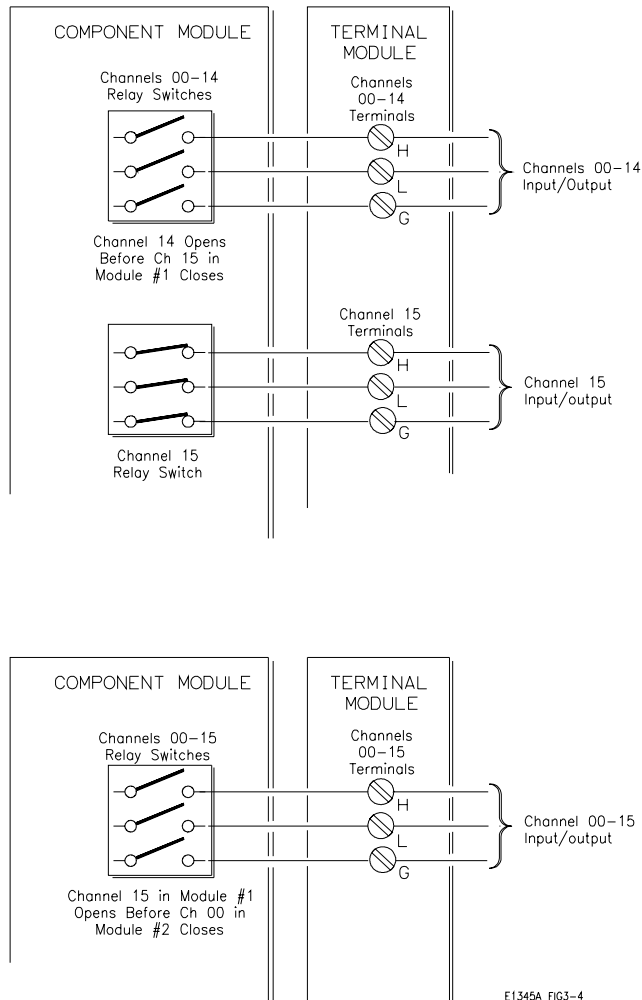

E1345A FIG3-4

**Figure 3-4. Scanning Channels 100 to 215 of a Two Module Switchbox**

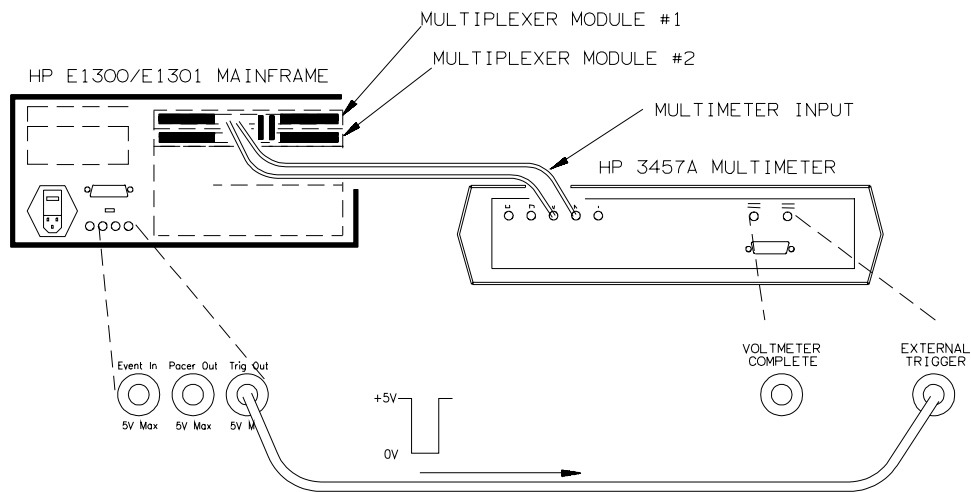

E1345 fig3-5

**Figure 3-5. Mainframe to Multimeter Connection for Synchronization**

### Example: Making 2-Wire Ohms Measurements by Scanning

Use the same setup shown in the first program example in this section, except change the commands in lines 10 and 40 to the following:

```
10 OUTPUT 722;"TRIG EXT;OHM"           !Set multimeter to 2-wire ohms.
40 OUTPUT 70914;"SCAN:MODE RES"       !Closes channel switches.
```

This command, when used with SCAN:PORT ABUS and SCAN <channel\_list> commands, automatically closes the channels defined in the channel list, and the AT and AT2 Tree Switches during scanning.

### Example: Making 4-Wire Ohms Measurements by Scanning

Use the SCAN:MODE FRES command to automatically close the selected channels defined in the SCAN <channel\_list> command. This type of measurement requires paired channel closure (e.g., channels 02 and 10), which the command automatically performs. Change the commands in lines 10 and 40 to the following:

```
10 OUTPUT 722;"TRIG EXT;OHM"           !Set multimeter to 4-wire ohms.
40 OUTPUT 70914;"SCAN:MODE FRES"       !Closes channel switches.
```

This command, when used with the SCAN:PORT ABUS and SCAN <channel\_list> commands, automatically closes the channels defined in the channel list and the AT and BT Tree Switches during scanning.

### Example: Making Multiple Scans

The ARM:COUN <number> command selects multiple scanning cycles. Add the command to the first program example in this section, as follows:

```
OUTPUT 70914;"ARM:COUN 10"             !Enables 10 scanning cycles.
OUTPUT 70914;"SCAN (@100:215)"        !Sets scan list.
```

### Example: Making Continuous Scans

The INIT:CONT ON command selects continuous scanning cycles (INIT:CONT OFF disables continuous scanning cycles). Add the command to the first program example in this section, as follows:

```
OUTPUT 70914;"INIT:CONT ON"           !Enables continuous scanning
                                        cycles.
OUTPUT 70914;"SCAN (@100:215)"        !Sets scan list.
```

### Comments

See Chapter 4 for more information on scanning.

**Scanning Requirements of a Switchbox (in an HP Mainframe with an HP Command Module).** To scan modules in a switchbox, you must:

- know the card numbers (see Chapter 1) of all the modules to be scanned;
- sequentially address the modules (e.g., Logical Address 112, 113, 114, etc.);
- set lowest addressed module to a logical address that is a multiple of 8 (see the *HP 75000 Series B Installation and Getting Started Guide*, or other appropriate manuals, for more information).

# Measuring Temperature Using Thermocouples (HP E1344A/47A Modules Only)

- Closing the AT and AT2 Tree Switches allows a multimeter connected to the AT Tree Switch Terminals to measure the voltage of a thermocouple or resistance of a thermistor connected to any channel.
- Closing the RT and AT2 Tree Switches allows a multimeter connected to the AT Tree Switch Terminals to measure the resistance of the thermistor on the terminal module.
- Use the thermistor resistance to calculate the temperature of the terminal module to compensate thermocouple temperature measurements (see “Comments” later in this section).

## Example: Setup for Measuring Thermocouple Temperature Using an External Multimeter

Figure 3-6 and the following commands show how to set up channel 01 of a single module switchbox to measure temperature of a thermocouple using an external multimeter. Execute:

CLOS (@192,193)

*192 and 193 close the AT2 and RT tree switches.*

measure thermistor temperature

*Use multimeter.*

OPEN (@193)

*Opens the RT Tree Switch.*

CLOS (@101,190)

*Closes channel 01 and the AT tree switch.*

measure thermocouple voltage; calculate compensated thermocouple voltage

*Use multimeter.*

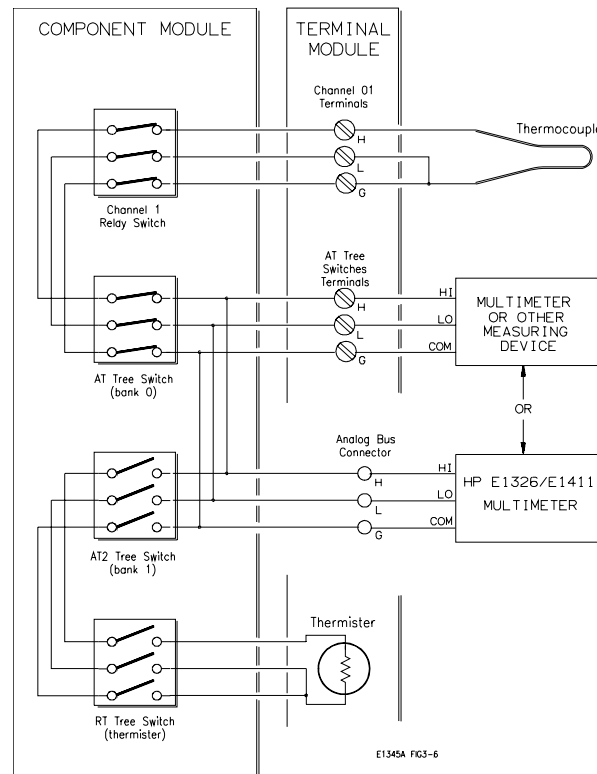

Figure 3-6. Temperature Measurement on Channel 01 Using a Thermocouple

**Comments** **Temperature Measurements using Thermistors.** This consists of 2-wire or 4-wire Ohms measurements. See “Connecting Switchbox Channels to Tree Terminals for Making Measurements” on page 34 for making those measurements.

**Measuring Temperature with the HP E1326/E1411 Multimeters.** The HP E1326/E1411 Multimeters can directly measure channels of single or multiple multiplexer modules. The multimeter automatically calculates the correct temperature for the specific thermistor or thermocouple type used. For more information, see the *HP E1326/E1411 Multimeter User's Manual*.

**Thermocouple Compensation using the Thermistor on the HP E1344A/47A Terminal Module.** The temperature inside the terminal module can affect the temperature reading taken from a thermocouple. Use the thermistor inside the terminal module to determine the temperature inside the terminal module to compensate the thermocouple temperature measurements. Do the following:

1. Measure the resistance of the thermistor on the terminal module. Compute the temperature of the terminal module from the reading ( $T_{ref}$ ).
2. For values of resistance between 92.7 to 3.685e6, use the following equations to calculate the temperature of the terminal module:  
 $T_{ref}$  = temperature in degrees C.  
Thermos = the resistance of channel x93, the 5K ohm thermistor.  
 $A = 1.28463e-3$   
 $B = .23625e-3$   
 $C = 9.2697e-8$   
 $W = \text{LOG}(\text{Thermos})$   
 $T_{ref} = 1./(A+W*(B +C*W*W))-273.15$
3. Measure the voltage on the thermocouple connected to a channel ( $V_t$ ).
4. Convert the thermistor temperature ( $T_{ref}$ ) to the thermocouple voltage ( $V_{ref}$ ). Use the temperature to voltage characteristics of the thermocouple measured in step 2 (different thermocouples have different temperature-to-voltage characteristics).
5. Compute the compensated voltage (V) by the formula:  
 $V = (V_t - V_{ref})$ .
6. Convert the compensated voltage (V) calculated in step 4 to temperature. This is the actual temperature measured by the thermocouple.



# Chapter 4

# Understanding the Relay Multiplexer Modules

---

## Using This Chapter

This chapter explains techniques to scan the channels of 16-Channel Relay and 16-Channel Thermocouple Relay Multiplexer Modules.

- [Commands for Scanning Switchbox Channels](#) . . . . . page 41
- [Using Scanning Trigger Sources](#) . . . . . page 41
- [Using the Scan Complete Bit](#) . . . . . page 46

## Commands for Scanning Switchbox Channels

Scanning multiplexer channels consists of closing a set of channels, one at a time. Available for the multiplexers are single, multiple (2 to 32767), or continuous scanning modes. See [Figure 4-1](#) for the different commands used in scanning.

## Using Scanning Trigger Sources

The TRIG:SOUR command specifies the source to advance the *channel list*. Use the TRIG command to advance the channel list while in the TRIG:SOUR BUS or TRIG:SOUR HOLD trigger state. To enable the HP E1300/E1301 Mainframe "Trig Out" port, use the OUTP command. [Figure 4-2](#) shows the different trigger sources. The sources are used in other HP VXibus mainframes with HP command modules that have "Trig Out" ports.

### Scanning with External Instruments

The examples on the following pages show different ways to scan channels of a switchbox in an HP E1300/E1301 Mainframe. The operation is similar to other HP VXibus mainframes with HP command modules that have "Trig Out" and "Event In" ports.

The computer used in the examples is an HP Series 200/300 used with HP BASIC as the program language. The computer interfaces with the mainframe over HP-IB. Assumed is an:

- HP-IB select code of 7;
- HP-IB primary address of 09 for the HP E1300/E1301 Mainframe;
- HP-IB primary address of 22 for the HP 3457A Multimeter;
- HP-IB secondary address of 14 for the multiplexer module.

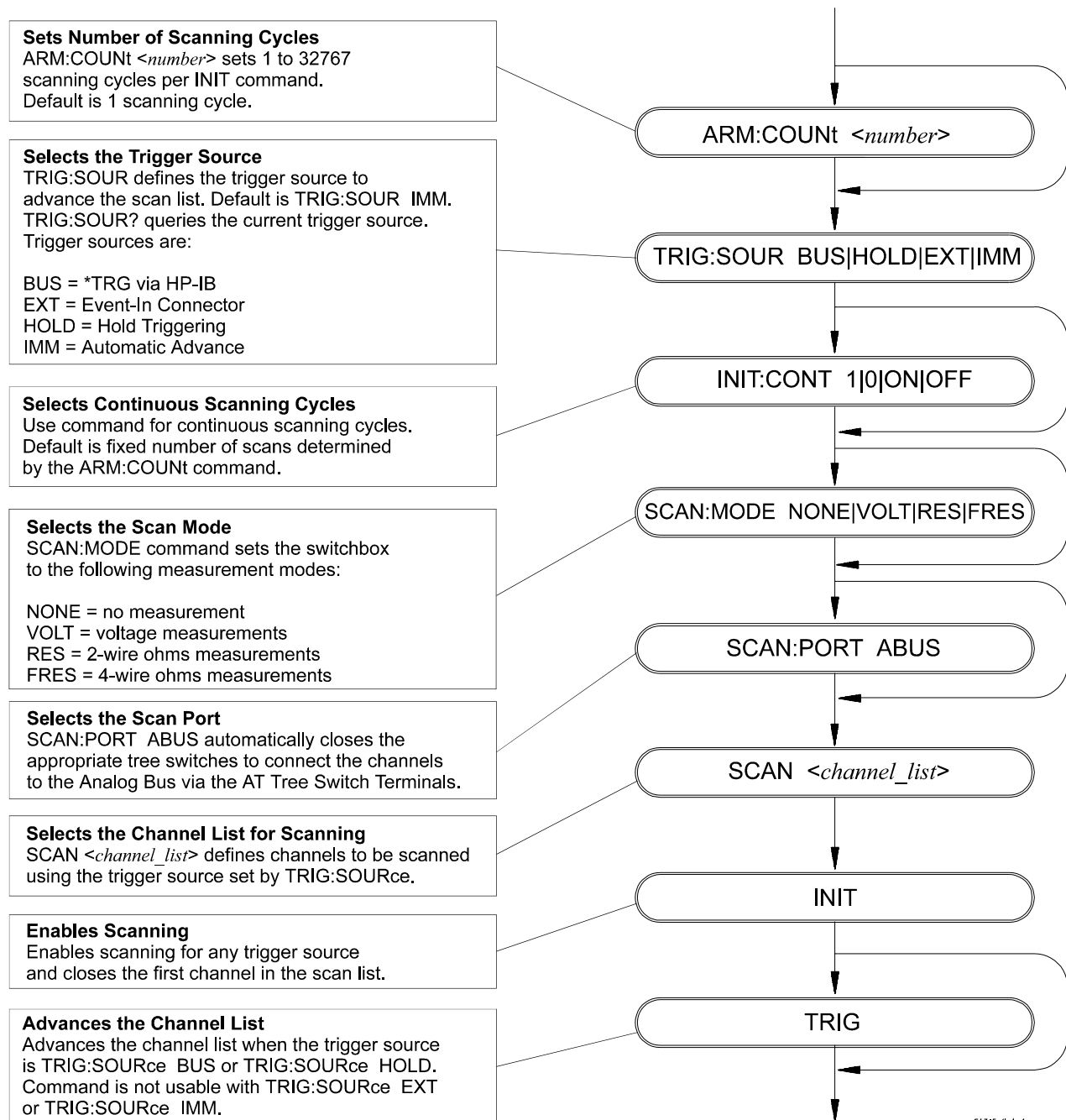
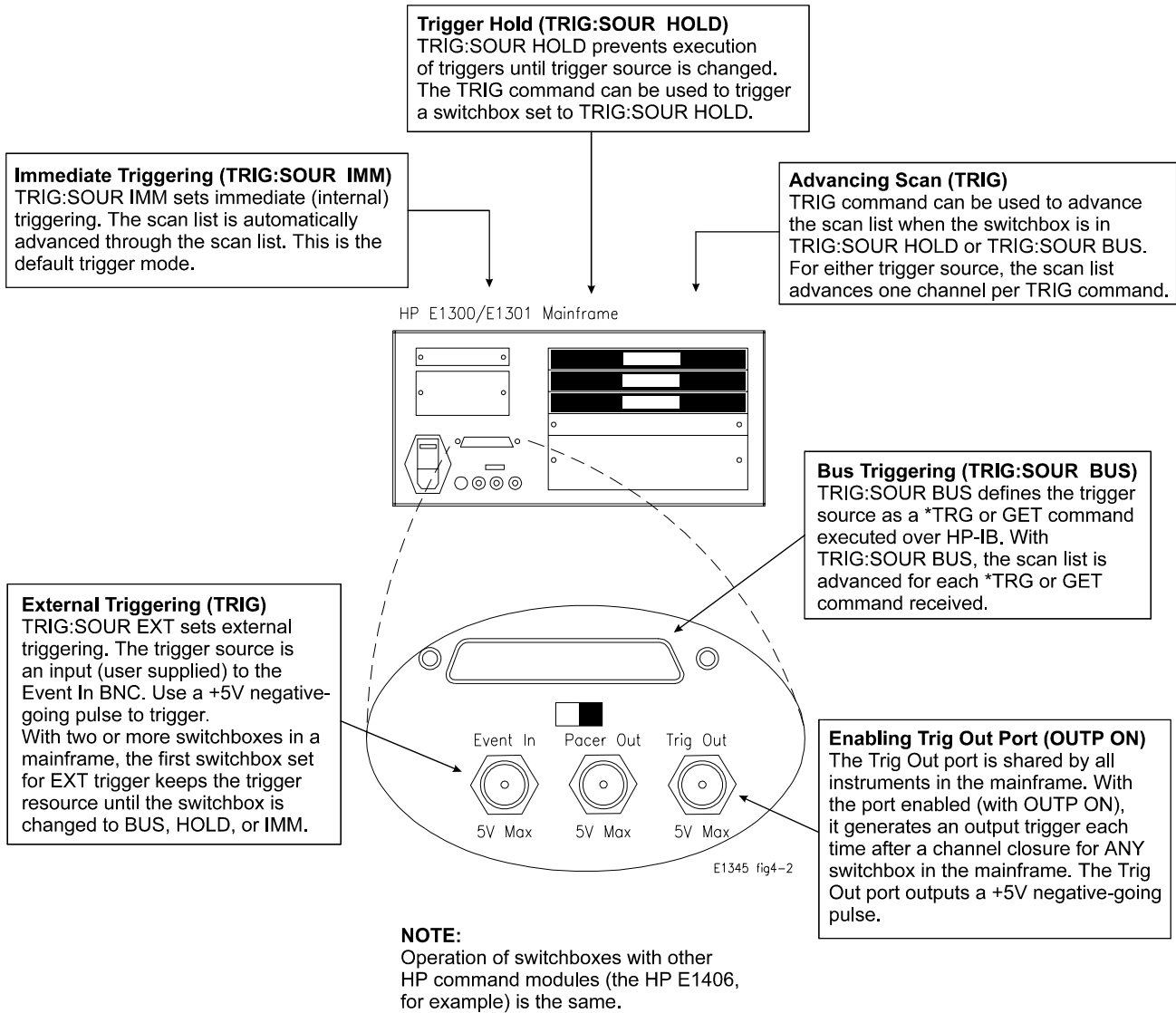

Figure 4-1. Scanning Commands



**Figure 4-2. Trigger Sources for Scanning**

## Example: Scanning With External Devices

This example uses the mainframe "Trig Out" port to synchronize the multiplexers to an HP 3457A Digital Multimeter. See the following figure for typical connections. For this example, use the trigger output pulse of the mainframe "Trig Out" port to trigger the multimeter via its External Trigger port. The sequence of operation is:

1. INIT (line 70) closes channel number 100.
2. The channel closure causes a trigger output from the "Trig Out" port.
3. The trigger causes the multimeter to make a measurement.
4. Measurement result is sent to the computer (lines 80 to 100).
5. TRIGGER (line 110) advances the channel list to the next channel.
6. Steps 2-5 are repeated for channels 101 through 115.

```

10 OUTPUT 722;"TRIG EXT;DCV"           !Sets multimeter to external
                                         !trigger and to measure dc volts.
20 OUTPUT 70914;"OUTP ON"              !Enables "Trig Out" port.
30 OUTPUT 70914;"TRIG:SOUR BUS"        !Sets switchbox to receive Bus
                                         !triggers.
40 OUTPUT 70914;"SCAN:MODE VOLT"      !Sets switchbox to measure
                                         !voltage.
50 OUTPUT 70914;"SCAN:PORT ABUS"      !Closes the AT and AT2 Tree
                                         !Switches.
60 OUTPUT 70914;"SCAN (@100:115)"     !Selects the channel list for
                                         !scanning.
70 OUTPUT 70914;"INIT"                 !Starts scanning cycle.
80 FOR I=1 TO 16                        !Start count loop.
90 ENTER 722;A                          !Enter reading into variable A.
100 PRINT A                             !Print reading in variable A.
110 TRIGGER 70914                       !Trigger the switchbox to
                                         !advance the channel list.
120 NEXT I
130 END

```

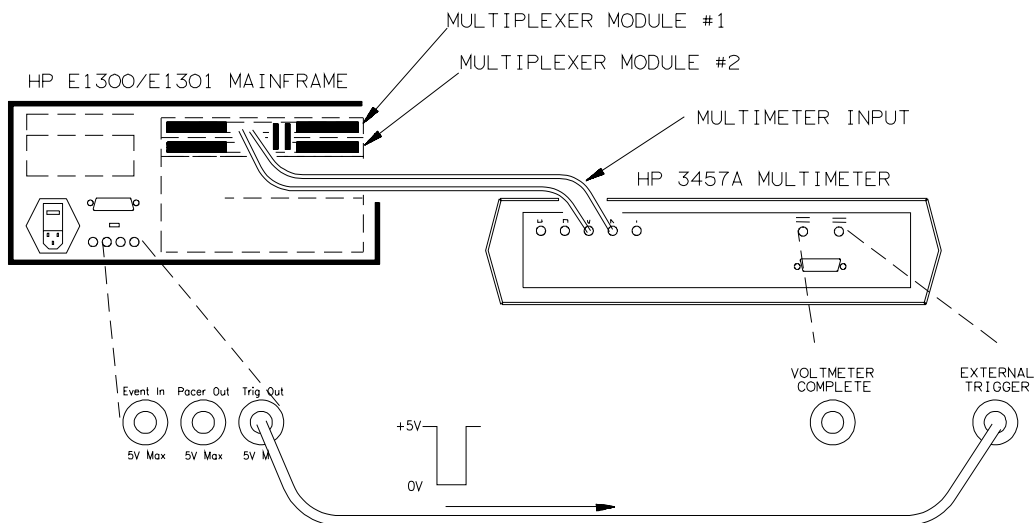

E1345 fig3-5

## Example: Scanning Using "Trig Out" and "Event In" Ports

This example uses the mainframe "Trig Out" and "Event In" ports to synchronize the multiplexers to an HP 3457A Digital Multimeter. See the following figure for typical connections. For this example, use the trigger output pulse of the mainframe "Trig Out" port to trigger the multimeter via its "EXTERNAL TRIGGER" port. Note that the pulse output from the multimeter's "VOLTMETER COMPLETE" port triggers the switchbox to advance the channel list. Use the multimeter's reading storage capability to store readings.

The sequence of operation is:

1. INIT (line 50) closes channel number 100.
2. The channel closure causes a trigger output from the "Trig Out" port.
3. The trigger causes the multimeter to make a measurement.
4. Measurement result is stored into multimeter memory.
5. Trigger is output from multimeter's "VOLTMETER COMPLETE" port.
6. Trigger to "Event In" port advances the channel list to the next channel.
7. Steps 2-6 are repeated for channels 101 through 115.

10 OUTPUT 722;"TRIG EXT;DCV;MEM FIFO"

*!Sets multimeter to external trigger; to measure dc volts, and store readings.*

20 OUTPUT 70914;"OUTP ON"

*!Enables "Trig Out" port.*

30 OUTPUT 70914;"TRIG:SOUR EXT"

*!Sets switchbox to receive external triggers.*

40 OUTPUT 70914;"SCAN (@100:115)"

*!Selects the channel list (channels 100 to 115).*

50 OUTPUT 70914;"INIT"

*!Starts scanning cycle.*

60 END

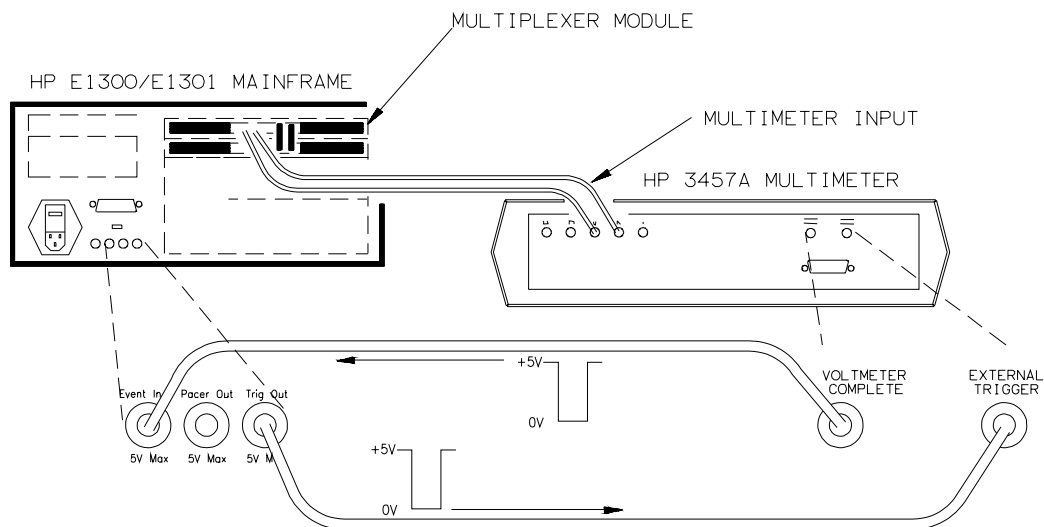

E1345 fig3-5

## Using the Scan Complete Bit

You can use the Scan Complete Bit (bit 8) in the Operation Status Register of a switchbox to determine when a scanning cycle completes (no other bits in the register apply to the switchbox). Bit 8 has a decimal value of 256 and you can read it directly with the STAT:OPER? command (refer to the STATus:OPERation[:EVENT]? command in Chapter 5 for an example).

When enabled by the STAT:OPER:ENAB 256 command, the Scan Complete Bit will be reported as bit 7 of the Status Register. Use the HP-IB Serial Poll or the IEEE 488.2 Common Command \*STB? to read the Status Register. When bit 7 of the Status Register is enabled by the \*SRE 128 Common Command to assert an HP-IB Service Request (SRQ), you can interrupt the controller when the Scan Complete Bit is set, after a scanning cycle completes. This allows the controller to do other operations while the scanning cycle is in progress.

The following example monitors bit 7 in the Status Register to determine when the scanning cycle completes. The computer used in the example is an HP Series 200/300 used with HP BASIC as the program language. The computer interfaces with the mainframe over HP-IB. The HP-IB select code is 7, the HP-IB primary address is 09, and the HP-IB secondary address is 14.

### Example: Scan Complete Interrupt

```
10 OUTPUT 70914;"*CLS" !Clear all switchbox status
                               structure.
20 OUTPUT 70914;"STAT:OPER:ENAB 256"
                               !Enable Scan Complete Bit to set
                               bit 7 in Status Register.
30 OUTPUT 70914;"*SRE 128"
                               !Enable bit 7 of Status Register
                               to assert SRQ.
40 OUTPUT 70914;"TRIG:SOUR EXT" !Set to external trigger mode.
50 OUTPUT 70914;"SCAN (@100:115)" !Select channels to be scanned.
60 OUTPUT 70914;"INIT" !Start scanning cycle.
70 WHILE NOT BIT(S POLL(70914),7) !Waiting for scan complete.
80 PRINT "DO OTHER OPERATION HERE" !Enter program lines for
                                       computer to do other operations.
90 END WHILE
100 PRINT "INTERRUPT GENERATED" !Program goes to this line after
                                       interrupt is generated by a
                                       completed scanning cycle.
110 END
```

# Relay Multiplexer Command Reference

---

## Using This Chapter

This chapter describes Standard Commands for Programmable Instruments (SCPI) and summarizes IEEE 488.2 Common (\*) Commands applicable to all four 16-Channel Relay Multiplexer Modules.

- [Command Types](#) . . . . . page 47
- [SCPI Command Reference](#) . . . . . page 49
- [IEEE 488.2 Common Commands](#) . . . . . page 71
- [Command Quick Reference](#) . . . . . page 72

## Command Types

Commands are separated into two types: IEEE 488.2 Common Commands and SCPI Commands.

### Common Command Format

The IEEE 488.2 standard defines the Common Commands that perform functions like reset, self-test, status byte query, etc. Common Commands are four or five characters in length, always begin with the asterisk character (\*), and may include one or more parameters. The command keyword is separated from the first parameter by a space character. Some examples of Common Commands are shown below:

```
*RST      *ESR 32   *STB?
```

### SCPI Command Format

SCPI commands perform functions like closing switches, making measurements, querying instrument states, or retrieving data. A subsystem command structure is a hierarchical structure that usually consists of a top level (or root) command, one or more lower level commands, and their parameters. The following example shows part of a typical subsystem:

```
[ROUTE:]
  CLOSe <channel_list>
  SCAN <channel_list>
  :MODE?
```

[ROUTE:] is the root command, CLOSe and SCAN are second level commands with parameters, and :MODE? is a third level command.

**Command Separator** A colon (:) always separates one command from the next lower level command as shown below:

```
ROUTe:SCAN:MODE?
```

Colons separate the root command from the second level command (ROUTe:SCAN) and the second level from the third level (SCAN:MODE?).

**Abbreviated Commands** The command syntax shows most commands as a mixture of upper and lower case letters. The upper case letters indicate the abbreviated spelling for the command. For shorter program lines, send the abbreviated form. For better program readability, you may send the entire command. The instrument will accept either the abbreviated form or the entire command.

For example, if the command syntax shows MEASure, then MEAS and MEASURE are both acceptable forms. Other forms of MEASure, such as MEASU or MEASUR will generate an error. You may use upper or lower case letters. Therefore, MEASURE, measure, and MeAsUrE are all acceptable.

**Implied Commands** Implied commands are those which appear in square brackets ([ ]) in the command syntax. (Note that the brackets are not part of the command and are not sent to the instrument.) Suppose you send a second level command but do not send the preceding implied command. In this case, the instrument assumes you intend to use the implied command and it responds as if you had sent it. Examine the SOURce subsystem shown below:

```
[SOURce:]  
PULSe  
:COUNT <count>  
:COUNT? [<MIN|MAX>]  
:PERiod <period>  
:PERiod? [<MIN|MAX>]
```

The root command [SOURce:] is an implied command. To set the instrument's pulse count to 25, you can send either of the following command statements:

```
SOUR:PULS:COUN 25    or    PULS:COUN 25
```



**Parameters** **Parameter Types.** The following table contains explanations and examples of parameter types you might see later in this chapter.

Parameter Type	Explanations and Examples
Numeric	Accepts all commonly used decimal representations of numbers including optional signs, decimal points, and scientific notation.  123, 123E2, -123, -1.23E2, .123, 1.23E-2, 1.23000E-01. Special cases include MIN, MAX, and INF.
Boolean	Represents a single binary condition that is either true or false.  ON, OFF, 1, 0.
Discrete	Selects from a finite number of values. These parameters use mnemonics to represent each valid setting.  An example is the TRIGger:SOURce <source> command where <i>source</i> can be BUS, EXT, HOLD, or IMM.

**Optional Parameters.** Parameters shown within square brackets ( [ ] ) are optional parameters. (Note that the brackets are not part of the command and are not sent to the instrument.) If you do not specify a value for an optional parameter, the instrument chooses a default value. For example, consider the ARM:COUNT? [<MIN|MAX>] command. If you send the command without specifying a parameter, the present ARM:COUNT value is returned. If you send the MIN parameter, the command returns the minimum count available. If you send the MAX parameter, the command returns the maximum count available. Be sure to place a space between the command and the parameter.

## Linking Commands

**Linking IEEE 488.2 Common Commands with SCPI Commands.** Use a semicolon between the commands. For example:

```
*RST;OUTP ON    or    TRIG:SOUR HOLD;*TRG
```

**Linking Multiple SCPI Commands.** Use both a semicolon and a colon between the commands. For example:

```
ARM COUN 1;:TRIG:SOUR EXT
```

## SCPI Command Reference

This section describes the Standard Commands for Programmable Instruments (SCPI) commands for the multiplexer modules. Commands are listed alphabetically by subsystem and also within each subsystem.

The ABORt subsystem stops a scan in progress when the scan is enabled via the interface, and the trigger modes are TRIGger:SOURce BUS or TRIGger:SOURce HOLD.

## Subsystem Syntax

ABORt

## Comments

- **ABORt Operation** invalidates the current channel list and sets ARM:COUNT 1 (one scanning cycles per INITiate command), sets INITiate CONTInuous OFF (no continuous scanning cycles), and sets TRIGger:SOURce IMMEDIATE (continuous internal triggering).

- **Stopping Scans Enabled from Interface:** When a scan is enabled from the interface, use an interface CLEAR command or the HP E1301 front panel "Reset Instr" or "Clear Instr" key to stop the scan.

When the scan is enabled from the interface and the trigger source is TRIGger:SOURce BUS or TRIGger:SOURce HOLD, use ABORt or the HP E1301 front panel "Reset Instr" or "Clear Instr" keys to stop the scan.

- **Stopping Scans Enabled from Front Panel:** When a scan is enabled from the HP E1301 front panel, execute \*RST over the interface or the front panel "Reset Instr" or "Clear Instr" keys to stop the scan.

- **Related Commands:** ARM, INITiate:CONTInuous, [ROUTe:]SCAN, TRIGger

## Example Stopping a Scan with ABORt

```
TRIG:SOUR BUS
INIT:CONT ON
SCAN (@100:115)
INIT
•
ABOR
```

*Bus is trigger source.  
Set continuous scanning.  
Sets channel list.  
Starts scanning cycle.  
  
Aborts scan in progress.*

The ARM subsystem selects the number of scanning cycles (1 through 32767) for each INITiate command.

```
ARM
:COUNT <number> MIN|MAX
:COUNT? [MIN |MAX]
```

## :COUNT

**ARM:COUNT <number> MIN|MAX** allows scanning cycles to occur a multiple of times (1 to 32767) with one INITiate command and when INITiate:CONTinuous OFF|0 is set.

### Parameters

Parameter Name	Parameter Type	Range of Values
<number>	numeric	1–32767 MIN MAX

### Comments

- **Number of Scans:** Use only values between 1 to 32767 for the number of scanning cycles (default is 1).
- **Related Commands:** ABORt, INITiate[:IMMediate]
- **\*RST Condition:** ARM:COUNT 1

### Example Setting Ten Scanning Cycles

```
ARM:COUN 10
SCAN (@100:115)
IINIT
```

*Sets 10 scanning cycles.  
Sets channel list.  
Starts scanning cycle.*

## :COUNT?

---

**ARM:COUNT? [MIN|MAX]** returns current number of scanning cycles set by ARM:COUNT. A value is supplied if no MIN or MAX parameter is sent. With MIN or MAX passed as parameters, MIN returns 1 and MAX returns 32767.

### Parameters

Parameter Name	Parameter Type	Range of Values
MIN MAX	numeric	MIN=1, MAX=32767

### Comments

- **Related Commands:** INITiate[:IMMEDIATE]

### Example Query Number of Scanning Cycles

```
ARM:COUN 10  
ARM COUN?
```

*Sets 10 scanning cycles.  
Query number of scanning cycles;  
returned value is 10.*

The DISPlay subsystem monitors the channel state of a selected module (or card) in a switchbox, and only operates with mainframes that have a display, such as the HP 75000 Series B Mainframe (HP Model Number E1301).

**Subsystem Syntax**

```
DISPlay
:MONitor
:CARD <number|AUTO>
[:STATe] <mode>
```

---

## :MONitor:CARD

---

**DISPlay:MONitor:CARD <number/AUTO>** selects the module in a switchbox to be monitored.

### Parameters

Parameter Name	Parameter Type	Range of Values
<number AUTO>	numeric	1–99

### Comments

- **Selecting a Specific Module to be Monitored:** Send the card number in a switchbox with the DISPlay:MONitor:CARD command.
- **Selecting the Present Module to be Monitored:** Use the DISPlay:MONitor AUTO command to select the last module addressed by a switching command (e.g., [ROUTE:]CLOSE).
- **\*RST Condition:** DISPlay:MONitor:CARD AUTO

### Example **Select Module #2 in a Switchbox for Monitoring**

DISP:MON:CARD 2

*Selects module #2 in a switchbox.*

## :MONitor[:STATe]

---

DISPlay:MONitor[:STATe] *<mode>* turns the monitor mode on or off.

### Parameters

Parameter Name	Parameter Type	Range of Values
<i>&lt;mode&gt;</i>	boolean	0 1 ON OFF

### Comments

- **Monitoring Switchbox Channels:** DISPlay:MONitor[:STATe] ON or DISPlay:MONitor[:STATe] 1 turns the monitor mode ON to show the channel state of the selected module. DISPlay:MONitor[:STATe] OFF or DISPlay:MONitor[:STATe] 0 turns the monitor mode OFF.

- **Selecting the Module to be Monitored:**  
Use the DISPlay:MONitor:CARD *<number>*/AUTO command to select the module.

- **Monitor Mode on an HP E1301A Mainframe Display:** The following shows the monitor mode on the display of an HP E1301 Mainframe.

```
SWITCH_112: Chan: 0,1, , , , , , , , ,
```

The example shows that channels 00 and 01 are closed.

- **\*RST Condition:** DISPlay:MONitor[:STATe] OFF|0

### Example Enabling the Monitor Mode

```
DISP:MON:CARD 2  
DISP:MON 1
```

*Selects module #2 in a switchbox.  
Turns the monitor mode on.*

The INITiate subsystem selects continuous scanning cycles and starts the scanning cycle.

**Subsystem Syntax**

```
INITiate
:CONTinuous <mode>
:CONTinuous?
[:IMMediate]
```

## :CONTinuous

**INITiate:CONTinuous <mode>** enables or disables continuous scanning cycles for the switchbox.

### Parameters

Parameter Name	Parameter Type	Range of Values
<mode>	boolean	0 1 ON OFF

### Comments

- **Continuous Scanning Operation:** Continuous scanning is enabled with the INITiate:CONTinuous ON or INITiate:CONTinuous 1 command. Sending the INITiate[:IMMediate] command closes the first channel in the *channel list*. Each trigger from a trigger source selected by the TRIGger:SOURce command advances the scan through the *channel list*. A trigger at the end of the *channel list* closes the first channel in the list and the scan cycle repeats.
- **Non-Continuous Scanning Operation:** Non-Continuous scanning is enabled with the INITiate:CONTinuous OFF or INITiate:CONTinuous 0 command. Sending the INITiate[:IMMediate] command closes the first channel in the *channel list*. Each trigger from a trigger source selected by the TRIGger:SOURce command advances the scan through the *channel list*. A trigger at the end of the *channel list* opens the last channel in the list and the scanning cycle stops.
- **Stopping Continuous Scans:** See the ABORt command.
- **Related Commands:** ABORt, ARM:COUNT, TRIGger, TRIGger:SOURce
- **\*RST Condition:** INITiate:CONTinuous OFF

### Example Enabling Continuous Scans

```
INIT:CONT ON
SCAN (@100:115)
INIT
```

*Enables continuous scanning.  
Sets channel list.  
Starts scanning cycle.*

## :CONTInuous?

---

**INITiate:CONTInuous?** queries the scanning state. With continuous scanning enabled, the command returns ON. With continuous scanning disabled, the command returns OFF.

### Example Query Continuous Scanning State

INIT:CONT ON  
INIT:CONT?

*Enables continuous scanning.  
Query continuous scanning state.*

## [:IMMEDIATE]

---

**INITiate[:IMMEDIATE]** starts the scanning cycle and closes the first channel in the *channel list*. Successive triggers from the source specified by the TRIGger:SOURce command advances the scan through the *channel list*.

### Comments

- **Starting the Scanning Cycle:** The INITiate[:IMMEDIATE] command starts scanning by closing the first channel in the *channel list*. A trigger advances the scan through the *channel list*. An invalid *channel list* generates an error (see the [ROUTE:]SCAN command).
- **Stopping Scanning Cycles:** See the ABORt command.

### Example Enabling a Single Scan

SCAN (@100:115)  
INIT

*Sets channel list.  
Starts scanning cycle.*



The OUTPut subsystem enables or disables the "Trig Out" port of the HP E1300/E1301 Mainframe.

**Subsystem Syntax**      OUTPut  
                                       [:STATe] <state>  
                                       [:STATe]?

## [:STATe]

**OUTPut[:STATe] <state>** enables/disables the "Trig Out" port on the rear panel of the HP E1300A/E1301A Mainframe. OUTPut[:STATe] ON|1 enables the port and OUTPut[:STATe] OFF|0 disables the port.

### Parameters

Parameter Name	Parameter Type	Range of Values
<state>	boolean	0 1 ON OFF

### Comments

- **Enabling "Trig Out" Port:** When enabled, the "Trig Out" is pulsed each time a channel is closed during scanning. When disabled, the "Trig Out" is not pulsed.
- **Output Pulse:** The pulse is a + 5 V negative-going pulse.
- **"Trig Out" Port Shared by Switchboxes:** When enabled, the "Trig Out" may be pulsed by any switchbox each time a channel is closed in a switchbox during scanning. To disable the output for a specific switchbox, send the OUTPut[:STATe] OFF or OUTPut[:STATe] 0 command for that switchbox.
- **Related Commands:** [ROUTE:]SCAN, TRIGger:SOURce
- **\*RST Condition:** OUTPut[:STATe] OFF (port disabled)

### Example      Enabling "Trig Out" Port

OUTP ON

*Enables "Trig Out" port for pulse output.*

## [:STATe]?

**OUTPut[:STATe]?** queries the present state of the "Trig Out" port. The command returns 1 if the port is enabled, or 0 if disabled.

### Example      Query "Trig Out" Port State

OUTP ON  
 OUTP:STAT?

*Enables "Trig Out" port for pulse output.  
 Query port enable state.*

The [ROUTE:] subsystem controls switching and scanning operations for the multiplexer modules in a switchbox.

**Subsystem Syntax**

```
[ROUTE:]
  CLOSe <channel_list>
  CLOSe? <channel_list>
  OPEN <channel_list>
  OPEN? <channel_list>
  SCAN <channel_list>
      :MODE NONE|VOLT|RES|FRES
      :MODE?
      :PORT ABUS|NONE
```

**CLOSe**

**[ROUTE:]CLOSe <channel\_list>** closes multiplexer channels specified in the *channel\_list*. The *channel\_list* is in the form (@ccnn), (@ccnn,ccnn), or (@ccnn:ccnn) where cc = card number (00–99) and nn = channel number (00–15).

**Parameters**

Parameter Name	Parameter Type	Range of Values
<channel_list>	numeric	cc00-cc15

**Comments**

- **Closing Channels:** To close:
  - a single channel, use [ROUTE:]CLOSe (@ccnn);
  - multiple channels, use [ROUTE:]CLOSe (@ccnn,ccnn);
  - sequential channels, use [ROUTE:]CLOSe (@ccnn:ccnn);
  - a group of sequential channels, use [ROUTE:]CLOSe (@ccnn:ccnn,ccnn:ccnn);
  - or any combination.
 Closure order for multiple channels with a single command is not guaranteed.
- **Closing the AT, BT, AT2, and RT Tree Switches:** Use channel numbers 90, 91, 92, and 93 to close the AT, BT, AT2, and RT Tree Switches, respectively.
- **Related Commands:** [ROUTE:]OPEN, [ROUTE:]CLOSe?
- **\*RST Condition:** All multiplexer channels are open.

**Example Closing Multiplexer Channels**

This example closes channel 00 of a card number 1 multiplexer module and channel 15 of a card number 2 multiplexer module in a single switchbox.

```
CLOS (@100,215)           100 closes channel 00 of multiplexer #1;
                          215 closes channel 15 of multiplexer #2.
```

## CLOSe?

---

**[ROUTE:]CLOSe? <channel\_list>** returns the current state of the channel(s) queried. The *channel\_list* is in the form (@ccnn). The command returns 1 if the channel is closed or returns 0 if the channel is open.

- Comments**
- **Query is Software Readback:** The [ROUTE:]CLOSe? command returns the current software state of the channel specified. It does not account for relay hardware failures.

**Example Query Multiplexer Channel Closure**

```
CLOS (@100,215)           100 closes channel 00 of multiplexer #1;
                          215 closes channel 15 of multiplexer #2.
CLOS? (@215)              Query channel 215
```

## OPEN

---

**[ROUTE:]OPEN <channel\_list>** opens the multiplexer channels specified in the *channel\_list*. The *channel\_list* is in the form (@ccnn), (@ccnn,ccnn), or (@ccnn:ccnn) where cc = card number (00–99) and nn = channel number (00–15).

**Parameters**

Parameter Name	Parameter Type	Range of Values
<channel_list>	numeric	cc00–cc15

- Comments**
- **Opening Channels:** To open:
    - a single channel, use [ROUTE:]OPEN (@ccnn);
    - for multiple channels, use [ROUTE:]OPEN (@ccnn,ccnn);
    - sequential channels, use [ROUTE:]OPEN (@ccnn:ccnn);
    - a group of sequential channels, use [ROUTE:]OPEN (@ccnn:ccnn,ccnn:ccnn);
    - or any combination.Opening order for multiple channels with a single command is not guaranteed.
  - **Opening the AT, BT, AT2, and RT Tree Switches:** Use channel numbers 90, 91, 92, and 93 to open the AT, BT, AT2, and RT Tree Switches, respectively.
  - **Related Commands:** [ROUTE:]CLOSe, [ROUTE:]OPEN?
  - **\*RST Condition:** All multiplexer channels are open.

**Example Opening Multiplexer Channels**

This example opens channel 00 of a card number 1 multiplexer module and channel 15 of a card number 2 multiplexer module in a single switchbox.

```
OPEN (@100,215)           100 opens channel 00 of multiplexer #1;
                          215 opens channel 15 of multiplexer #2.
```

## OPEN?

---

[ROUTE:]OPEN? <channel\_list> returns the current state of the channel(s) queried. The *channel\_list* is in the form (@ccnn). The command returns 1 if the channel is open or returns 0 if the channel is closed.

- Comments**
- **Query is Software Readback:** The [ROUTE:]OPEN? command returns the current software state of the channel specified. It does not account for relay hardware failures.

**Example Query Multiplexer Channel Open State**

```
OPEN (@100,215)           100 opens channel 00 of multiplexer #1;
                           215 opens channel 15 of multiplexer #2.
OPEN? (@215)              Query channel 215.
```

## SCAN

---

[ROUTE:]SCAN <channel\_list> defines the channels to be scanned. The *channel\_list* is in the form (@ccnn), (@ccnn,ccnn), or (@ccnn:ccnn) where cc = card number (00–99) and nn = channel number (00–15).

**Parameters**

Parameter Name	Parameter Type	Range of Values
<channel_list>	numeric	cc00-cc15

- Comments**
- **Defining the Channel List:** When executing [ROUTE:]SCAN, the channel list is checked for valid card and channel numbers. An error is generated for an invalid *channel list*.
  - **Scanning Operation:** With a valid *channel list*, INITiate[:IMMEDIATE] starts the scanning cycle and closes the first channel in the *channel list*. Successive triggers from the source specified by TRIGger:SOURce advances the scan through the *channel list*.
  - **Stopping Scan:** See the ABORt command.
  - **Closing the AT, BT, and AT2 Tree Switches:**  
See the [ROUTE:]SCAN:PORT ABUS command.
  - **Related Commands:** TRIGger, TRIGger:SOURce
  - **\*RST Condition:** All channels open.

**Example Scanning Using External Devices**

The following example shows how to scan channels using the HP E1300/E1301 Mainframe via HP-IB and an HP 3457A Digital Multimeter. This example uses the mainframe "Trig Out" port to synchronize the multiplexer module in a switchbox to the multimeter. The trigger pulse from the port triggers the multimeter for a measurement. See Chapter 3 for typical user connections to the multiplexer.

The computer used in the example is an HP Series 200/300 with HP BASIC as the program language. The computer interfaces with the mainframe over HP-IB. Assumed is an HP-IB select code of 7, an HP-IB primary address of 09 and 22 for the HP E1300/E1301 Mainframe and HP 3457A Multimeter, respectively, and an HP-IB secondary address of 14 for the switchbox.

```

10 OUTPUT 722;"TRIG EXT;DCV"           !Sets multimeter to external trigger and to
                                         measure dc volts.
20 OUTPUT 70914;"OUTP ON"              !Enables "Trig Out" port.
30 OUTPUT 70914;"TRIG:SOUR BUS"       !Sets switchbox to receive Bus triggers.
40 OUTPUT 70914;"SCAN:MODE VOLT"     !Sets switchbox to measure voltage
                                         during scanning.
50 OUTPUT 70914;"SCAN:PORT ABUS"     !Sets switchbox to close the appropriate
                                         Tree Switches during scanning.
60 OUTPUT 70914;"SCAN (@100:115)"    !Selects the channel list.
70 OUTPUT 70914;"INIT"                !Starts scanning cycle.
80 FOR I=1 TO 16                       !Start count loop.
90 ENTER 722;A                          !Enter reading into variable A.
100 PRINT A                             !Print reading in variable A.
110 TRIGGER 70914                       !Trigger the switchbox to advance the
                                         channel list.
120 NEXT I                              !Increment count.
130 END

```

## SCAN:MODE

---

**[ROUTe:]SCAN:MODE <mode>** sets the multiplexer channels defined by the [ROUTe:]SCAN <channel\_list> command for None, Volts, 2-wire Ohms, or 4-wire Ohms measurements.

### Parameters

Parameter Name	Parameter Type	Range of Values
<mode>	discrete	NONE VOLT RES FRES

### Comments

- **Order of Command Execution:** The [ROUTe:]SCAN:MODE command must be executed before the [ROUTe:]SCAN <channel\_list> command.
- **NONE and VOLT Mode Description:** Channel list is setup for volts measurements.
- **RES Mode Description:** Channel list is setup for 2-wire ohms measurements.
- **FRES Mode Description:** Channel list is setup for 4-wire ohms measurements. Use channels only in Bank 0 (channels 00 to 07) when selecting the channels with the [ROUTe:]SCAN <channel\_list> command. Any channel that closes in Bank 0 automatically closes the paired channel in Bank 1 (e.g., channels 02 and 10). Selecting a channel in Bank 1 (channels 08 to 15) causes an error.
- **\*RST Condition:** ROUT:SCAN:MODE NONE

### Example Selecting the 4-Wire Ohms Mode

```
TRIG:SOUR EXT  
SCAN:MODE FRES  
SCAN (@100:107)  
INIT
```

*Selects external trigger source.  
Selects the 4-wire ohms scanning mode.  
Sets channel list.  
Starts scanning cycle.*

## SCAN:MODE?

---

**[ROUTe:]SCAN:MODE?** returns the current state of the scan mode. The command returns NONE, VOLT, RES, or FRES if the scan mode is in the NONE, VOLT, RES, or FRES mode, respectively.

### Example Query Scan Mode

Since this example selects the FRES (4-wire ohms) mode, the query command returns FRES.

```
SCAN:MODE FRES  
SCAN:MODE?
```

*Selects the 4-wire ohms scanning mode.  
Query the scanning mode.*

## SCAN:PORT

---

**[ROUTe:]SCAN:PORT <port>** enables/disables the closing of the AT, BT, and AT2 tree switches during scanning. SCAN:PORT ABUS closes the appropriate tree switches (for Analog Bus connections). For correct operation, set the measurement modes by the [ROUTe:]SCAN:MODE command. The [ROUTe:]SCAN:PORT NONE command prevents closing the tree switches.

### Parameters

Parameter Name	Parameter Type	Range of Values
<port>	discrete	ABUS NONE

### Comments

- **Order of Command Execution:** The [ROUTe:]SCAN:PORT command must be executed before the [ROUTe:]SCAN <channel\_list> command.
- **\*RST Condition:** [ROUTe:]SCAN:PORT NONE

### Example Selecting the ABUS Port

```
TRIG:SOUR EXT  
SCAN:MODE FRES  
SCAN:PORT ABUS  
SCAN (@100:107)  
INIT
```

*Selects external trigger source.  
Selects the 4-wire ohms scanning mode.  
Selects the ABUS port.  
Sets channel list.  
Starts scanning cycle.*

The STATUS subsystem reports the bit values of the Operation Status Register. Enables the Status Register to set a bit after a bit is set to 1 by the Operation Status Register.

**Subsystem Syntax**     STATus  
                              :OPERation  
                              :ENABle <number>  
                              [:EVENT]?

---

## :OPERation:ENABle

---

**STATus:OPERation:ENABle <number>** enables the Operation Status Register to set a bit in the Status Register. For multiplexer modules, when bit 8 in the Operation Status Register is set to 1, bit 7 in the Status Register is set to 1.

### Parameters

Parameter Name	Parameter Type	Range of Values
<number>	numeric	1–32768

### Comments

- **Setting Bit 7 of the Status Register:** STATus:OPERation:ENABle 256 sets bit 7 of the Status Register to 1 after bit 8 of the Operation Status Register is set to 1.
- **Related Commands:** [ROUTE:]SCAN

### Example     Enable the Status Register

STAT:OPER:ENAB 256

*Enables bit 7 of the Status Register.*

## :OPERation[:EVENT]?

---

**STATus:OPERation[:EVENT]?** returns the bit value of the Operation Status Register (only bit 8 is used by the multiplexer modules).

- Comments**
- **Setting Bit 8 of the Operation Status Register:** Bit 8 (Scan Complete) is set to 1 after a scanning cycle completes. Bit 8 returns to 0 after sending the STATus:OPERation[:EVENT]? command.
  - **Returned Data after sending the STATus:OPERation[:EVENT]? Command:** The command returns +256 if bit 8 of the Operation Status Register is set to 1. The command returns +0 if bit 8 of the Operation Status Register is set to 0.
  - **Related Commands:** [ROUTE:]SCAN

**Example**    **Reading the Operation Status Register after a Scanning Cycles**

STAT:OPER?

read and print the register value

*Returns the bit values of the Standard Operation Status Register.  
+256 shows bit 8 is set to 1;  
+0 shows bit 8 is set to 0.*



The SYSTEM subsystem returns error numbers/messages in the error queue of a switchbox, and returns module types and descriptions in a switchbox.

**Subsystem Syntax**

```

SYSTEM
:CDEscription? <number>
:CPON <number|ALL>
:CTYPE? <number>
:ERRor?
    
```

## :CDEscription?

**SYSTEM:CDEscription? <number>** returns the description of a selected module (card) in a switchbox.

### Parameters

Parameter Name	Parameter Type	Range of Values
<number>	numeric	1-99

### Comments

- **16-Channel Relay Multiplexer Module Description:** The SYSTEM:CDEscription? <number> command returns:

```

16 Channel High Voltage Relay Mux for the HP E1343A;
16 Channel High Voltage Mux with T/C for the HP E1344A;
16 Channel Relay Mux for the HP E1345A; and
16 Channel Relay Mux with T/C for the HP E1347A.
    
```

### Example Reading the Description of a Card #1 Module

```

SYST:CDES? 1 Determines the description.
    
```

## :CPON

---

**SYSTem:CPON** <number/ALL> opens all channels of a selected or all modules (cards) in a switchbox.

### Parameters

Parameter Name	Parameter Type	Range of Values
<number>	numeric	1–99

### Comments

- **Differences between \*RST and CPON:** SYSTem:CPON only opens all channels of a selected or all modules in a switchbox. \*RST opens all channels of all modules in a switchbox and also sets the trigger, etc. modes to the power-on states.

### Example **Setting a Card #1 Module to its Power-on State**

SYST:CPON 1 *Sets module #1 to power-on state.*

## :CTYPE?

---

**SYSTem:CTYPE?** <number> returns the module (card) type of a selected module in a switchbox.

### Parameters

Parameter Name	Parameter Type	Range of Values
<number>	numeric	1–99

### Comments

- **16-Channel Relay Multiplexer Module Model Number:**

The SYSTem:CTYPE? <number> command returns:

```
HEWLETT-PACKARD , E1343A , 0 , A.01.00 (E1343A)
HEWLETT-PACKARD , E1344A , 0 , A.01.00 (E1344A)
HEWLETT-PACKARD , E1345A , 0 , A.01.00 (E1345A)
HEWLETT-PACKARD , E1347A , 0 , A.01.00 (E1347A)
```

Note: The 0 after the module number is the serial number of the module (always 0). A.01.00 is an example of the module revision code number.

### Example **Reading the Model Number of a Card #1 Module**

SYST:CTYP? 1 *Determines the model number.*

## :ERRor?

---

**SYSTem:ERRor?** returns the error numbers and corresponding error messages in the error queue of a switchbox. See Appendix C for a listing of the switchbox error numbers and messages.

### Comments

- **Error Numbers/Messages in the Error Queue:** Errors generated by a switchbox store an error number and corresponding error message in the error queue. The error number is always a negative number. Each error message can be up to 255 characters long.
- **Clearing the Error Queue:** An error number/message is removed from the queue each time the SYSTem:ERRor? command is sent. The errors are cleared first-in, first-out. When the queue is empty, each following SYSTem:ERRor? command returns 0, "No error". To clear all error numbers/messages in the queue, execute \*CLS.
- **Maximum Error Numbers/Messages in the Error Queue:** The queue holds a maximum of 30 error numbers/messages for each switchbox. If the queue overflows, the last error number/message in the queue is replaced by -350, "Too many errors". The oldest error numbers/messages remain in the queue and the most recent are lost.

### Example Reading the Error Queue

SYST:ERR?

*Query the error queue.*

The TRIGger subsystem commands controls the triggering operation of the multiplexer modules in a switchbox.

**Subsystem Syntax**      TRIGger  
                                  [:IMMediate]  
                                  :SOURce BUS|EXTernal|HOLD|IMMediate  
                                  :SOURce?

## [:IMMediate]

---

**TRIGger[:IMMediate]** causes a trigger to occur when the defined trigger source is TRIGger:SOURce HOLD or TRIGger:SOURce BUS.

- Comments**
- **Executing the TRIGger[:IMMediate] Command:** A *channel list* must be defined with [ROUte:]SCAN <channel\_list> and an INITiate[:IMMediate] command must be executed before TRIGger[:IMMediate] can trigger the switchbox.
  - **HOLD or BUS Source Remains:** If selected, the TRIGger:SOURce HOLD or TRIGger:SOURce BUS commands remain in effect after triggering the switchbox with the TRIGger[:IMMediate] command.
  - **Related Commands:** INITiate, [ROUte:]SCAN

**Example      Advancing Scan using the TRIGger Command**

TRIG:SOUR HOLD	<i>Sets trigger source to hold.</i>
SCAN (@100:115)	<i>Sets channel list.</i>
INIT	<i>Starts scanning cycle.</i>
loop statement	<i>Start count loop.</i>
TRIG	<i>Advances channel list to next channel.</i>
increment loop	<i>Increment count loop.</i>

## :SOURce

---

**TRIGger:SOURce BUS|EXTeRnal|HOLD|IMMeDiate** specifies the trigger source to advance the channel list during scanning.

### Parameters

Parameter Name	Parameter Type	Range of Values
BUS	discrete	*TRG command
EXTeRnal	discrete	Event In BNC port
HOLD	discrete	Hold triggering
IMMeDiate	discrete	Continuous triggering

### Comments

- **Enabling the Trigger Source:** The TRIGger:SOURce command only selects the trigger source. The INITiate[:IMMeDiate] command enables the trigger source.
- **Using the TRIG Command:** You can use TRIGger[:IMMeDiate] to advance the scan when TRIGger:SOURce BUS or TRIGger:SOURce HOLD is selected.
- **Using External Trigger Inputs:** With TRIGger:SOURce EXTeRnal selected, only one switchbox at a time can use the external trigger input at the HP E1300/E1301 Mainframe "Event In" port. The trigger input is assigned to the first switchbox requesting the external trigger source.
- **Assigning External Trigger:** A switchbox assigned with TRIG:SOUR EXT remains assigned to that source until it receives a command to change the source to BUS, HOLD, or IMMeDiate. When the source is changed, the external trigger source is available to another switchbox (with a TRIGger:SOURce EXTeRnal command). Another switchbox cannot receive an external trigger source if the source is already assigned, or an error is generated.
- **Using Bus Triggers:** To trigger the switchbox with TRIGger:SOURce BUS selected, use the IEEE 488.2 common command \*TRG or the HP-IB Group Execute Trigger (GET).
- **"Trig Out" Port Shared by Switchboxes:** See the OUTPut command.
- **Related Commands:** [ROUte:]SCAN, TRIGger, ABORt
- **\*RST Condition:** TRIGger:SOURce IMMeDiate

### Example Scanning Using External Triggers

In the following example, the trigger input is applied to the HP E1300/E1301 Mainframe "Event In" port.

```
TRIG:SOUR EXT
SCAN (@100:115)
INIT
trigger externally
```

```
Sets trigger source to external.
Sets channel list.
Starts scanning cycle.
Advances channel list to next channel.
```

## Scanning Using Bus Triggers

TRIG:SOUR BUS  
SCAN (@100:115)  
INIT  
\*TRG

*Select interface (BUS) triggering.  
Sets channel list.  
Starts scanning cycle.  
Advances scan using BUS triggering.*

## :SOURce?

---

**TRIGger:SOURce?** returns the current trigger source for the switchbox. Command returns either BUS, EXT, HOLD, or IMM for trigger sources BUS, EXTERNAL, HOLD, or IMMEDIATE, respectively.

### Example Query Trigger Source

TRIG:SOUR EXT  
TRIG:SOUR?

*Sets trigger source to external.  
Query trigger source; returns EXT.*

# IEEE 488.2 Common Commands

The following table lists the IEEE 488.2 Common (\*) Commands that all four 16-Channel Relay Modules accept. The operation of some of these commands is described in Chapter 4 of this manual. For more information on Common Commands, refer to the *HP 75000 Series B Mainframe User's Manual* (HP Model Number E1300/E1301) or the *ANSI/IEEE Standard 488.2-1987*.

Command	Title	Description
*IDN? *RST *TST?	Identification Reset Self-Test	Returns identification string of the switchbox. Opens all channels, and invalidates current <i>channel list</i> for scanning. Sets ARM:COUN 1, TRIG:SOUR IMM, and INIT:CONT OFF. Always returns 0.
*OPC *OPC? *WAI	Operation Complete Operation Complete Query Wait to Complete	See note below. See note below. See note below.
*CLS *ESE *ESE? *ESR? *SRE *SRE? *STB?	Clear status Event status enable Event status enable query Event status register query Service request enable Service request enable query Read status byte query	Clears all status registers (see STATus:OPERation[:EVENT]?). See note below. See note below. See note below. Enables status register bits (see Chapter 4 for operation). See note below. See note below.
*TRG	Trigger	Triggers the switchbox to advance the scan when scan is enabled and trigger source is TRIGger:SOURce BUS.
*RCL *SAV	Recall instrument state Store instrument state	See note below. See note below.
<p>Note: These commands apply to many instruments and are not documented in detail here. See the <i>HP 75000 Series B E1300/E1301 Mainframe User's Manual</i> or the <i>ANSI/IEEE Standard 488.2-1987</i> for more information.</p>		

# Command Quick Reference

The following tables summarize SCPI and IEEE 488.2 Common (\*) Commands for the multiplexer modules used in a switchbox.

## SCPI Commands Quick Reference

Command	Description
ABORt	Abort a scan in progress.
ARM :COUNT <number> MIN MAX :COUNT? [MIN   MAX]	Multiple scans per INIT command. Query number of scans.
DISPlay :MONitor:CARD <number> AUTO :MONitor[:STATe] <mode>	Selects module to be monitored. Selects monitor mode.
INITiate :CONTinuous <mode> :CONTinuous? [:IMMediate]	Enables/disables continuous scanning. Query mode. Starts a scanning cycle.
OUTPut [:STATe] <mode> [:STATe]?	Enables/disables "Trig Out" pulse. Query state of trig out pulse.
[ROUte:] CLOSe <channel_list> CLOSe? <channel_list> OPEN <channel_list> OPEN? <channel_list> SCAN <channel_list> SCAN:MODE NONE VOLT RES FRES SCAN:MODE? SCAN:PORT NONE ABUS	Close channel(s). Query channel(s) closed. Open channel(s). Query channel(s) opened. Define channels for scanning. Selects appropriate Channel Switches for Measurements. Query state of scan mode. Enables Tree Switches closure as part of a Measurement.
STATus :OPERation:ENABLE :OPERation[:EVENT]?	Enables the Operation Status Register to set a bit in the Status Register. Returns status of Operation Status Register.
SYSTem :CDEscription? <number> :CPON <number> ALL :CTYPE? <number> :ERRor?	Returns description of module in a switchbox. Sets specified module to its power-on state. Returns the module type. Returns error number/message in a switchbox Error Queue.
TRIGger [:IMMediate] :SOURce BUS :SOURce EXTernal :SOURce HOLD :SOURce IMMEDIATE :SOURce?	Causes a trigger to occur. Trigger source is *TRG. Trigger source is "Event In" BNC. Hold off triggering. Continuous (internal) triggers. Query scan trigger source.

## IEEE 488.2 Common Commands Quick Reference

Command	Title	Description
*RST	Reset	Opens all channels, invalidates current channel list for scanning. Sets ARM:COUN 1, TRIG:SOUR IMM, and INIT:CONT OFF.
*TRG	Bus Trigger	When scan is enabled and trigger source is TRIG:SOUR BUS, use the *TRG command to trigger the switchbox to advance the scan.
*TST?	Self Test	Always returns 0.



# Appendix A

## 16-Channel Relay Multiplexer Specifications

### HP E1343A/44A 16-Channel Relay Multiplexer

<p><b>Maximum Voltage:</b> Terminal to Terminal: 250 Vdc or <math>a_{c_{rms}}</math>; 354 V Peak Terminal to Chassis: 250 Vdc or <math>a_{c_{rms}}</math>; 354 V Peak</p> <p><b>Maximum Current per Channel:</b> 50 mA (non-inductive)</p> <p><b>Maximum Power per Channel:</b> 1 VA</p> <p><b>Thermal Offset per Channel:</b> &lt;10<math>\mu</math>V (differential H-L)</p> <p><b>Closed Channel Resistance:</b> 100 <math>\Omega</math> <math>\pm</math> 10% (the value of the protection resistors)</p> <p><b>Insulation Resistance (Between any two points):</b> &gt;10<sup>9</sup> <math>\Omega</math> (at 40°C, 65% RH)</p> <p><b>Relay Life:</b> @ No Load: 10<sup>8</sup> Operations @ Rated Load: 10<sup>7</sup> Operations</p> <p><b>Bandwidth (-3dB):</b> Z(source) = Z(load) = 50 <math>\Omega</math> (Protection resistors shorted) &gt;10 MHz</p> <p><b>Channel-Channel Crosstalk (Typical) (50 <math>\Omega</math> Source &amp; Load):</b></p> <table style="margin-left: 20px; border: none;"> <tr><td>1 kHz</td><td>-80 dB</td></tr> <tr><td>10 kHz</td><td>-80 dB</td></tr> <tr><td>100 kHz</td><td>-80 dB</td></tr> <tr><td>1 MHz</td><td>-60 dB</td></tr> <tr><td>10 MHz</td><td>-40 dB</td></tr> </table> <p><b>Closed-Channel Capacitance:</b> High-Low &lt;150 pF Low-Guard &lt;150pF Guard-Chassis &lt;2000pF</p>	1 kHz	-80 dB	10 kHz	-80 dB	100 kHz	-80 dB	1 MHz	-60 dB	10 MHz	-40 dB	<p><b>Reference Junction Measurement Accuracy (HP E1344A only):</b> 0.4° C (over 18° to 28° C, operating temperature)</p> <p><b>Screw Terminal Wire Size:</b> 16 AWG Max; 26 Min</p> <p><b>Module Size/Device Type:</b> B, register-based</p> <p><b>Connectors Used:</b> P1</p> <p><b>Number of Slots:</b> 1</p> <p><b>VXIbus Interface Capability:</b> Interrupter, D16</p> <p><b>Interrupt Level:</b> 1-7, selectable</p> <p><b>Power Requirements:</b></p> <table style="margin-left: 20px; border: none;"> <tr> <td>Voltage</td> <td style="text-align: center;"><u>+5</u></td> <td style="text-align: center;"><u>+12</u></td> </tr> <tr> <td>Peak module current, IPM (A):</td> <td style="text-align: center;">0.20</td> <td style="text-align: center;">0.13</td> </tr> <tr> <td>Dynamic module current, IDM (A):</td> <td style="text-align: center;">0.01</td> <td style="text-align: center;">0.01</td> </tr> </table> <p><b>Watts/Slot:</b> 1.0</p> <p><b>Cooling/Slot:</b> 0.02 mm H<sub>2</sub>O @ 0.10 liter/sec</p> <p><b>Humidity:</b> 65% 0° to 40° C,</p> <p><b>Operating Temperature:</b> 0° to 55° C,</p> <p><b>Storage Temperature:</b> - 40° to 75° C,</p> <p><b>EMC, RFI, Safety:</b> meets FTZ1046/1984, CSA556B, IEC348, UL1244</p> <p><b>Net Weight (kg):</b> 0.9</p>	Voltage	<u>+5</u>	<u>+12</u>	Peak module current, IPM (A):	0.20	0.13	Dynamic module current, IDM (A):	0.01	0.01
1 kHz	-80 dB																			
10 kHz	-80 dB																			
100 kHz	-80 dB																			
1 MHz	-60 dB																			
10 MHz	-40 dB																			
Voltage	<u>+5</u>	<u>+12</u>																		
Peak module current, IPM (A):	0.20	0.13																		
Dynamic module current, IDM (A):	0.01	0.01																		

# HP E1345A/47A 16-Channel Relay Multiplexer

<p><b>Maximum Voltage:</b> Terminal to Terminal: 120 Vdc or <math>a_{c_{rms}}</math>: 170 V Peak Terminal to Chassis: 120 Vdc or <math>a_{c_{rms}}</math>: 170 V Peak</p> <p><b>Maximum Current per Channel:</b> 50 mA (non-inductive)</p> <p><b>Maximum Power per Channel:</b> 1 VA</p> <p><b>Thermal Offset per Channel:</b> &lt;4 <math>\mu</math>V (differential H-L)</p> <p><b>Closed Channel Resistance:</b> 100 <math>\Omega</math> <math>\pm</math>10% (the value of the protection resistors)</p> <p><b>Insulation Resistance (Between any two points):</b> &gt;10<sup>9</sup> <math>\Omega</math> (at 40°C, 65% RH)</p> <p><b>Relay Life:</b> @ No Load: 10<sup>8</sup> Operations @ Rated Load: 10<sup>7</sup> Operations</p> <p><b>Bandwidth (-3dB):</b> Z(source) = Z(load) = 50 <math>\Omega</math> (Protection resistors shorted) &gt;10 MHz</p> <p><b>Channel-Channel Crosstalk (Typical) (50 <math>\Omega</math> Source &amp; Load):</b></p> <table border="0"> <tr><td>1 kHz</td><td>-80 dB</td></tr> <tr><td>10 kHz</td><td>-80 dB</td></tr> <tr><td>100 kHz</td><td>-80 dB</td></tr> <tr><td>1 MHz</td><td>-60 dB</td></tr> <tr><td>10 MHz</td><td>-40 dB</td></tr> </table> <p><b>Closed-Channel Capacitance:</b> High-Low &lt;150 pF Low-Guard &lt;150pF Guard-Chassis &lt;2000pF</p>	1 kHz	-80 dB	10 kHz	-80 dB	100 kHz	-80 dB	1 MHz	-60 dB	10 MHz	-40 dB	<p><b>Reference Junction Measurement Accuracy (HP E1347A only):</b> 0.3°C (over 18° to 28°C, operating temperature)</p> <p><b>Screw Terminal Wire Size:</b> 16 AWG Max; 26 Min</p> <p><b>Module Size/Device Type:</b> B, register-based</p> <p><b>Connectors Used:</b> P1</p> <p><b>No. Slots:</b> 1</p> <p><b>VXIbus Interface Capability:</b> Interrupter, D16</p> <p><b>Interrupt Level:</b> 1-7, selectable</p> <p><b>Power Requirements:</b></p> <table border="0"> <tr><td>Voltage</td><td><math>\pm</math>5</td><td><math>\pm</math>12</td></tr> <tr><td>Peak module current, IPM (A):</td><td>0.20</td><td>0.13</td></tr> <tr><td>Dynamic module current, IDM (A):</td><td>0.01</td><td>0.01</td></tr> </table> <p><b>Watts/Slot:</b> 1.0</p> <p><b>Cooling/Slot:</b> 0.02 mm H<sub>2</sub>O @ 0.10 liter/sec</p> <p><b>Humidity:</b> 65% 0° to 40°C</p> <p><b>Operating Temperature:</b> 0° to 55°C</p> <p><b>Storage Temperature:</b> - 40° to 75°C</p> <p><b>EMC, RFI, Safety:</b> meets FTZ1046/1984, CSA556B, IEC348, UL1244</p> <p><b>Net Weight (kg):</b> 0.9</p>	Voltage	$\pm$ 5	$\pm$ 12	Peak module current, IPM (A):	0.20	0.13	Dynamic module current, IDM (A):	0.01	0.01
1 kHz	-80 dB																			
10 kHz	-80 dB																			
100 kHz	-80 dB																			
1 MHz	-60 dB																			
10 MHz	-40 dB																			
Voltage	$\pm$ 5	$\pm$ 12																		
Peak module current, IPM (A):	0.20	0.13																		
Dynamic module current, IDM (A):	0.01	0.01																		

# Relay Life

Electromechanical relays are subject to normal wear-out. Relay life depends on several factors. The effects of loading and switching frequency are briefly discussed below:

**Relay Load.** In general, higher power switching reduces relay life. In addition, capacitive/inductive loads and high inrush currents (e.g., turning on a lamp or starting a motor) reduces relay life. *Exceeding specified maximum inputs can cause catastrophic failure.*

**Switching Frequency.** Relay contacts heat up when switched. As the switching frequency increases, the contacts have less time to dissipate heat. The resulting increase in contact temperature also reduces relay life.

## End of Life Detection

A preventative maintenance routine can prevent problems caused by unexpected relay failure. The end of the life of the relay can be determined by using the three methods described below. The best method (or combination of methods), as well as the failure criteria, depends on the application in which the relay is used.

**Contact Resistance.** As the relay begins to wear out, its contact resistance increases. When the resistance exceeds a predetermined value, the relay should be replaced.

**Stability of Contact Resistance.** The stability of the contact resistance decreases with age. Using this method, the contact resistance is measured several (5-10) times, and the variance of the measurements is determined. An increase in the variance indicates deteriorating performance.

**Number of Operations.** Relays can be replaced after a predetermined number of contact closures. However, this method requires knowledge of the applied load and life specifications for the applied load.

## Replacement Strategy

The replacement strategy depends on the application. If some relays are used more often, or at a higher load, than the others, the relays can be individually replaced as needed. If all the relays see similar loads and switching frequencies, the entire circuit board should be replaced when the end of life approaches. The sensitivity of the application should be weighed against the cost of replacing relays with some useful life remaining.

---

**Note** Relays that wear out normally or fail due to misuse should not be considered defective and are not covered by the product's warranty.

---

*Notes:*

---

# 16-Channel Relay Multiplexer Registers

## Register Addressing

Register addresses for register-based devices are located in the upper 25% of VXI A16 address space. Every VXI device (up to 256 devices) is allocated a 64 byte (32 word) block of addresses. The Multiplexer uses six of the 64 addresses allocated.

Figure B-1 shows the register address location within A16. Figure B-2 shows the location of A16 address space in the HP E1300/01 Mainframe and HP E1405/06 Command Module.

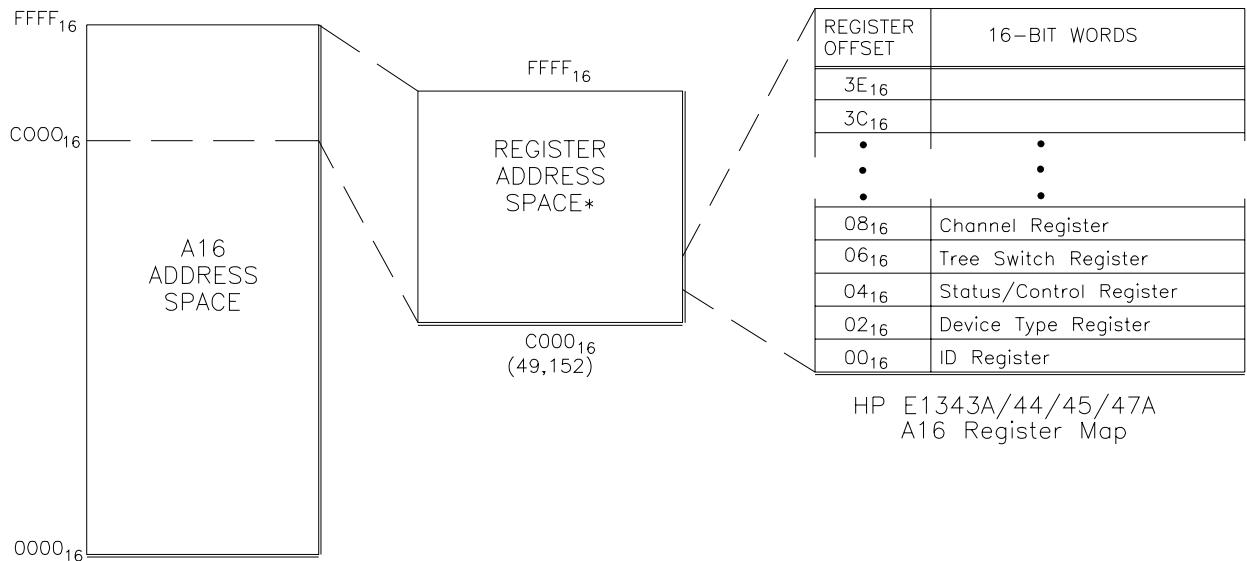

$$* \text{ Base Address} = C000_{16} + (\text{logical address} * 64)_{16}$$

$$\text{or}$$

$$49,152 + (\text{logical address} * 64)_{10}$$

$$\text{Register Address} = \text{Base Address} + \text{Register Offset}$$

E1345A F\_C\_1

Figure B-1. Relay Multiplexer Registers within A16 Address Space

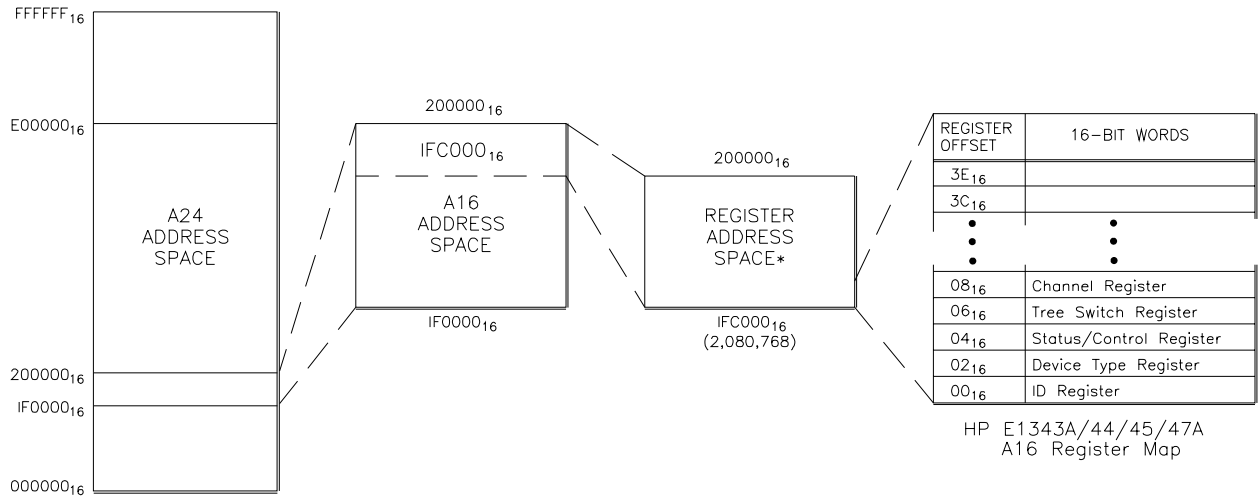

$$* \text{ Base Address} = \text{IFC000}_{16} + (\text{logical address} * 64)_{16}$$

$$\text{or}$$

$$2,080,768 + (\text{logical address} * 64)_{10}$$

$$\text{Register Address} = \text{Base Address} + \text{Register Offset}$$

E1345A F\_C\_2

**Figure B-2. Multiplexer Registers within HP E1300/E1406 A16 Address Space**

### The Base Address

When you are reading or writing to a multiplexer register, a hexadecimal or decimal register address is specified. This address consists of an A16 base address plus a register offset or register number.

The A16 base address used in register-based programming depends on whether the A16 address space is located inside the E1300(01) Mainframe, E1405/06 Command Module, or elsewhere (e.g., embedded computer). [Figure B-1](#), [Figure B-2](#), and [Figure B-1](#) enable you to determine the base address for the following computer configurations:

- E1300/E1301 Instrument BASIC (IBASIC)
- External Computer over HP-IB to E1300/E1301 Mainframe or E1405/06 Command Module
- V/382 Embedded Controller (C-Size system)

### Computer Configurations

This section contains performance and functional information on the computer configurations that can be used with register-based programming.

## Throughput Speed

Throughput speed is based on the amount of command parsing and whether the registers are accessed from the VXI backplane or from the HP-IB. The computer configurations which allow faster throughput relative to each other are summarized below.

1. HP E1499A V/382 Controller with READIO and WRITEIO (register access is from VXI backplane).
2. E1300/01 IBASIC absolute addressing with READIO and WRITEIO (register access is from VXI backplane).
3. E1300/01 IBASIC select code 8 with READIO and WRITEIO (register access is from VXI backplane).
4. External Computer using DIAG:PEEK? and DIAG:POKE (register access is over HP-IB).
5. External Computer using VXI:READ? and VXI:WRITE (register access is over HP-IB).

**Table B-1. Computer Configurations used with Relay Multiplexers**

Computer	Programming Method	Base Address
E1300/E1301 IBASIC  (Absolute Addressing)        (Select Code 8)	READIO (-9826,Base_addr + offset)  WRITEIO -9826,Base_addr + offset;data  (positive select code = byte read or write negative select code = word read or write)  READIO (8,Base_addr + reg number)  WRITEIO 8,Base_addr + reg number;data	Base_addr = $1FC000_{16} + (LADDR * 64)_{16}$  or  $= 2,080,768 + (LADDR * 64)$  offset = register offset (Figure B-1)  Base_addr = $LADDR * 256$  reg number = offset (Figure B-1)/2
External Computer  (over HP-IB to E1300/E1301 Mainframe or E1405/E1406 Command Module)	VXI:READ? logical_address,offset  VXI:WRITE logical_address,offset,data  DIAG:PEEK? Base_addr + offset,width  DIAG:POKE Base_addr + offset,width,data	logical address setting (LADDR)  offset = register offset (Figure B-1)  Base_addr = $1FC000_{16} + (LADDR * 64)_{16}$  or  $= 2,080,768 + (LADDR * 64)$  offset = register offset (Figure B-1)
V/382 Embedded Computer  (C-Size system)	READIO (-16,Base_addr + offset)  WRITEIO -16,Base_addr + offset;data  (positive select code = byte read or write negative select code = word read or write)	Base_addr = $C000_{16} + (LADDR * 64)_{16}$  or  $= 49,152 + (LADDR * 64)$  offset = register offset (Figure B-2)
LADDR : logical address. (LADDR * 64) <sub>16</sub> : multiply quantity, then convert to a hexadecimal number (e.g. $80 * 64)_{16} = 1400_{16}$ . When using DIAG:PEEK? and DIAG:POKE, the width (number of bits) is 8 or 16.		

## Embedded Computer Programming (C-Size Systems)

If the relay multiplexer is part of a C-Size VXI system, the fastest throughput is achieved using an embedded computer. The embedded computer allows you to access the registers from the VXIbus backplane, and thus, there is no parsing of SCPI command headers.

## IBASIC Programming

When the relay multiplexer is programmed using the E1300/E1301 Mainframe's Instrument BASIC (IBASIC), two methods of accessing the registers are through absolute addressing or using select code 8.

## Absolute Addressing and Select Code 8

Absolute addressing is faster than select code 8 since the complete register address (including the A16 starting location  $1FC000_{16}$ ) is specified. When select code 8 is used, the IBASIC processor must calculate the complete register address based on the logical address specified (Figure B-1).

## The Register Offset and Register Number

Depending on whether absolute addressing or select code 8 is used, either a register offset or register number is specified as part of the register address. Absolute addressing specifies a register offset, which is the register's location in the block of 64 address bytes. For example, the multiplexer's Channel Register has an offset of  $08_{16}$ . When you write a command to this register, the offset is added to the base address to form the register address (using a logical address of 80):

$$\begin{aligned}\text{register address} &= \text{base address} + \text{register offset} \\ &= 1FC000_{16} + (80 * 64)_{16} + 08_{16} \\ &= 1FC000_{16} + 1400_{16} + 08_{16} = \mathbf{1FD408}_{16} \\ \text{or} \\ &= 2,080,768 + (80 * 64) + 8 \\ &= 2,080,768 + 5120 + 8 = \mathbf{2,085,896}\end{aligned}$$

Using select code 8 requires that you specify a **register number**. The register number is the register offset/2. Referring to Figure B-1, the Channel Register with an offset of 08, is register number 4.

## External Computer Programming

When the multiplexer is programmed by an external computer through the E1300/E1301 Mainframe or E1405/E1406 Command Module, the registers are accessed using DIAG:PEEK? and DIAG:POKE, or VXI:READ? and VXI:WRITE.

DIAG:PEEK?/DIAG:POKE and VXI:READ?/VXI:WRITE

Throughput speed using DIAG:PEEK? and DIAG:POKE is faster than VXI:READ? and VXI:WRITE because the complete register address (including the A16 starting location  $1FC000_{16}$ ) is specified. VXI:READ? and VXI:WRITE specify the device logical address and register offset only. Thus, the E1300/E1406 processor must calculate the complete register address which decreases throughput speed.

IBASIC programming using absolute addressing or select code 8 is faster than either DIAG:PEEK? and DIAG:POKE or VXI:READ? and VXI:WRITE because the registers are accessed from the VXIbus backplane rather than from the HP-IB. Also, READIO and WRITEIO are not parsed.



## Reading the Registers

You can read the following multiplexer registers:

- ID Register (base +00<sub>16</sub>)
- Device Type Register (base +02<sub>16</sub>)
- Status Control Register (base +04<sub>16</sub>)
- Tree Switch Registers (base +06<sub>16</sub>)
- Channel Registers (base +08<sub>16</sub>)

### ID and Device Type Registers

**ID Registers:** Reading this register returns FFFF<sub>16</sub>. This shows Hewlett-Packard as the manufacturer and that the module is an A16 register based device.

**Device Type Register:** Reading this register returns:

ID	Model	Description
FF00	E1345A	16-Channel 3 Wire Relay Multiplexer
FF01	E1343A	16-Channel 3 Wire High Voltage Relay Multiplexer
FF02	E1347A	16-Channel Thermocouple Relay Multiplexer
FF03	E1344A	16-Channel Thermocouple High Voltage Relay Multiplexer
FF04	E1355A	8-Channel 120 Ohm Strain Relay Multiplexer
FF06	E1356A	8-Channel 350 Ohm Strain Relay Multiplexer

### Status Control Register

Each channel requires about 1 msec to close or open (2 msec for a close/open cycle). During this time, and also during a reset, the multiplexer is "busy". The Status Register returns the following:

"busy": FFF7<sub>16</sub>

"not busy": FFFF<sub>16</sub>

### Tree Switch and Channel Registers

Always returns FFFF<sub>16</sub> regardless of channel/tree switch state.

## Writing to the Registers

You can write to the following multiplexer registers:

- Status Control Register (base +04<sub>16</sub>)
- Tree Switch Registers (base +06<sub>16</sub>)
- Channel Registers (base +08<sub>16</sub>)

### Status Control Register

Writing a "1" to bit 0 of this register resets the interface circuitry to its power-on state and opens all channels. This is the only allowable write to this register.

Bit 7 is the only bit that has meaning when reading this register. The busy bit will go true for about 1 msec after a write to either the Tree Switch Register or the Channel Registers. The transition of the busy bit from "busy" to "not busy" corresponds to a backplane interrupt occurring. A backplane interrupt always occurs after a channel write.

### Tree Switches and Channel Registers

Writing a "1" to these registers closes the channel/tree switch and writing a "0" opens the channel/tree switch.

### Resetting the Module

To reset the module:

1. Write a "1" to bit 0 of the Status Control Register
2. Wait 100 usec
3. Write a "0" to bit 0 of the Status Control Register

NOTE: The busy bit in this case does not indicate when the relays have settled.

### Changing Channels

1. Write to the Tree Switch and Channel Registers.
2. Wait for busy to go to "1" or for a backplane interrupt.

## Register Definitions

The 16-Channel Relay Multiplexer Modules are register-based devices. See [Figure B-3](#) for register definitions.

### ID Register

Base +00 <sub>16</sub>	15	14	13	12	11	10	9	8	7	6	5	4	3	2	1	0
Write	Undefined								(Logical Address)							
Read*	Reg-Base		A16		Manufacturer ID											

\* Returns FFFF<sub>16</sub> =Hewlett-Packard A16 only register-based

### Device Type Register

Base +02 <sub>16</sub>	15	14	13	12	11	10	9	8	7	6	5	4	3	2	1	0
Write	Undefined															
Read*	1 (A16 only)				Module ID Code											

\* Returns: FF00<sub>16</sub> =16-Channel Relay Multiplexer (E1345A)

FF01<sub>16</sub> =16-Channel High Voltage Relay Multiplexer (E1343A)

FF02<sub>16</sub> =16-Channel Thermocouple Relay Multiplexer (E1347A)

FF03<sub>16</sub> =16-Channel Thermocouple High Voltage Relay Multiplexer (E1344A)

### Status/Control Register

Base +04 <sub>16</sub>	15	14	13	12	11	10	9	8	7	6	5	4	3	2	1	0	
Write*	Undefined															R	
Read**									B								

\* R =Multiplexer reset to power-on state (all switches open)

\*\* B =Status "busy" is true low in bit #7 (FF7F<sub>16</sub>)

### Tree Switch Register

Base +06 <sub>16</sub>	15	14	13	12	11	10	9	8	7	6	5	4	3	2	1	0
Write*	Undefined												93	92	91	90
Read	Always returns FFFF <sub>16</sub>															

\* Write "1" closes switch, write "0" opens switch

### Channel Registers

Base +08 <sub>16</sub>	15	14	13	12	11	10	9	8	7	6	5	4	3	2	1	0
Write*	CH15	CH14	CH13	CH12	CH11	CH10	CH09	CH08	CH07	CH06	CH05	CH04	CH03	CH02	CH01	CH00
Read	Always returns FFFF <sub>16</sub>															

\* Write "1" closes channel, write "0" opens channel

Figure B-3. Multiplexer Register Definitions

*Notes:*

---

# Appendix C

## 16-Channel Relay Multiplexer Error Messages

---

Figure C-1 lists the error messages associated with the multiplexer modules programmed by SCPI. See the appropriate Mainframe manual for a complete list of error messages.

**Table C-1. 16-Channel Relay Multiplexer Error Numbers/Messages**

Number	Title	Potential Cause(s)
-211	Trigger ignored	Trigger received when scan not enabled. Trigger received after scan complete. Trigger too fast.
-213	Init Ignored	Attempting to execute an INIT command when a scan is already in progress.
-224	Illegal parameter value	Attempting to execute a command with a parameter not applicable to the command.
+1500	External trigger source already allocated	Assigning an external trigger source to a switchbox when the trigger source has already been assigned to another switchbox.
+2000	Invalid card number	Addressing a module (card) in a switchbox that is not part of the switchbox.
+2001	Invalid channel number	Attempting to address a channel of a module in a switchbox that is not supported by the module (e.g., channel 99 of a multiplexer module).
+2006	Command not supported on this card	Sending a command to a module (card) in a switchbox that is unsupported by the module.
+2008	Scan list not initialized	Executing a scan without the INIT command.
+2009	Too many channels in channel list	Attempting to address more channels than available in the switchbox.
+2012	Invalid Channel Range	Invalid channel(s) specified in SCAN <channel_list> command. Attempting to begin scanning when no valid channel list is defined.
+2600	Function not supported on this card	Sending a command to a module (card) in a switchbox that is not supported by the module or switchbox.
+2601	Channel list required	Sending a command requiring a channel list without the channel list.

*Notes:*

---

### Symbols

- \*CLS, 71
- \*ESE, 71
- \*ESE?, 71
- \*ESR?, 71
- \*IDN, 71
- \*OPC, 71
- \*OPC?, 71
- \*RCL, 71
- \*RST, 71-72
- \*SAV, 71
- \*SRE, 46, 71
- \*SRE?, 71
- \*STB?, 46, 71
- \*TRG, 71-72
- \*TST?, 71-72
- \*WAI, 71

### A

- A16 Address Space, 77-78
- Abbreviated Commands, 48
- ABORt Command, 50
- Absolute Addressing, 80
- Adding
  - current shunts, 27-28
  - signal conditioning components, 27-28
- Address
  - channel, 16
  - logical, 14-15, 23-25
    - verifying, 25
  - registers, 77-79
  - switch, setting, 23
- Analog Bus, 12, 22, 34-35
  - cables, 12, 22, 36
  - connecting, 22, 34-36
  - connector, 12, 22, 34-36
- ARM Subsystem, 51-52
- ARM#COUNT, 31, 38, 51
- ARM#COUNT?, 52
- AT Tree Switch, 11-13
  - closing, 34, 38-39
  - connecting terminals, 36
  - opening, 35
- AT2 Tree Switch, 11, 13
  - closing, 38-39

- opening, 35
- Attenuator Configuration, 27-28

### B

- Bank Channels, 11, 32, 34
- Base Address, 78-79
- Block Diagram, 13
- Boolean Command Parameters, 49
- BT Tree Switch, 11-13
  - closing, 34, 38
  - opening, 35
- Bus Triggers, using, 70

### C

- Cables, analog bus, 12, 22
- Capacitance, closed-channel, 73-74
- Card
  - ID, setting, 23
  - numbers, 14-16, 33, 38
- Caution, 19
- Changing Channels, 82
- Channel
  - address, 16
  - changing, 82
  - closing, 16-17, 32, 58
  - closing multiple, 33
  - closing/opening order, 33
  - common, 11, 32
  - connecting to common, 32
  - connecting to tree terminals, 34-35
  - connections, 11-13
  - descriptions, 11-12
  - lists, 58-60
  - measuring, 11
  - opening, 33, 59
  - opening multiple, 33
  - query open/closed, 33, 59-60
  - register, 80-83
  - relay switches, 11
  - scanning, 60
    - a range of, 36
    - commands used, 41
    - switchbox, 41, 60-61
  - selecting, 14

- switches, 11
- Closing
  - channels, 16–17, 32, 58
  - multiple channels, 33
  - order for multiple channels, 33
- \*CLS, 71
- Command Reference, 47–72
- Commands
  - abbreviated, 48
  - IEEE 488.2, 47, 71
  - implied, 16, 48
  - linking, 49
  - optional, 16, 48
    - parameters, 49
  - parameters, 49
  - quick reference, 72
  - scanning, 42
  - scanning switchbox channels, 41
  - SCPI, 47–49, 72
    - format, 16, 47
  - separator, 48
  - types, 47–49
- Common (\*) Commands, 47
  - \*CLS, 71
  - \*ESE, 71
  - \*ESE?, 71
  - \*ESR?, 71
  - \*IDN?, 71
  - \*OPC, 71
  - \*OPC?, 71
  - \*RCL, 71
  - \*RST, 71–72
  - \*SAV, 71
  - \*SRE, 46, 71
  - \*SRE?, 71
  - \*STB?, 46, 71
  - \*TRG, 71–72
  - \*TST?, 71–72
  - \*WAI, 71
  - format, 47
  - list of, 71
  - quick reference, 72
- Common Terminals, 11, 32
- Computer Configurations, 79
- Configuring
  - multiplexer modules, 19–30
  - scanning voltmeter, 24
  - switchbox, 25
- Connecting
  - analog bus, 22, 34–36
  - channels to common, 32
  - channels to tree terminals, 34–35

- field wiring, 20
- user inputs, 29
- Connector
  - analog bus, 12
  - pins, 29
- Control Register, 81
  - definition, 83
  - writing to, 82
- Current
  - maximum allowed, 19
  - shunts, 27–28
  - source direct, 13
  - source tree, 13
  - specifications, 73–74

## D

- Device Type Register, 83
  - reading, 81
- DIAG#PEEK?, 79–80
- DIAG#POKE, 79–80
- Discrete Command Parameters, 49
- DISPlay Subsystem, 53–54
- DISPlay#MONitor#CARD, 53
- DISPlay#MONitor#STATe, 54

## E

- Embedded Computer Programming, 80
- Error
  - messages, 85
  - numbers, 85
  - queue, 67
- \*ESE, 71
- \*ESE?, 71
- \*ESR?, 71
- Event In Port, 41
  - scanning using, 45
- Examples
  - closing channels, 17
  - connecting channels to common, 32
  - connecting channels to tree terminals, 34–35
  - initial operation, 17
  - making continuous scans, 38
  - making multiple scans, 38
  - measure voltage by scanning, 36
  - measuring thermocouple temperature, 39
  - resetting the switchbox, 17
  - scan complete interrupt, 46
  - scanning 2-wire ohms measurements, 38
  - scanning 4-wire ohms measurements, 38
  - scanning using event in port, 45



scanning using trig out port, 45  
scanning with external devices, 44, 60–61

#### External

computer programming, 80  
devices, scanning with, 60–61  
trigger port, 44–45  
triggers, scanning with, 69

## F

Field Wiring, connecting, 20  
Five Volt Excitation for Strain Gages, 27

## G

Getting Started, 11–18  
Guidelines, wiring, 20

## H

#### HP-IB

interface select code, 17, 41, 46  
primary address, 17, 41, 46  
secondary address, 17, 41, 46  
service request (SRQ), 46

## I

IBASIC Programming, 80  
ID Register, 83  
    reading, 81  
\*IDN, 71  
IEEE 488.2 Commands  
    Common (\*) Commands, 47  
Implied Commands, 16, 48  
Initial Operation, 17  
INITiate Subsystem, 55–56  
INITiate#CONTinuous, 31, 38, 55  
INITiate#CONTinuous?, 56  
INITiate#IMMEDIATE, 31, 56  
Insulation Resistance, 73–74  
Interrupt  
    generating, 26  
    level, 73–74  
    lines, 26  
    priority, selecting, 26  
    scan complete, 46

## J

#### Jumper

card ID, 23  
interrupt priority, 26  
JM1 and JM2, 27

terminal module, 12

## L

Linking Commands, 49  
Logical Address, 14–15, 23  
    changing, 23  
    factory setting, 23  
    scanning voltmeter, 24  
    switch, setting, 23  
    switchbox, 25  
    verifying settings, 25  
Low Pass Filter Configuration, 27–28

## M

#### Measure

2-wire ohms, 34  
    by scanning, 38  
4-wire ohms, 35  
    by scanning, 38  
channels, 11  
multiplexer channels, 11  
resistance, 34  
temperature  
    using multimeters, 40  
    using thermistors, 40  
    using thermocouples, 39–40  
thermistor, 12  
    resistance, 39  
thermocouple voltage, 39  
voltage, 34  
    by scanning, 36  
    with multimeters, 35

Modules, terminal, 11, 20–21

#### Multimeter

external trigger port, 44–45  
measuring with, 35, 39–40  
primary address, 41  
voltmeter complete port, 45

#### Multiplexer Module

block diagram, 13  
card numbers, 14  
changing channels, 82  
channel, 11–13  
    address, 16  
    connections, 11–13  
channels, 11  
command reference, 47–72  
configuring, 19–27, 29–30  
description, 11  
error messages, 85

- error numbers, 85
- initial operation, 17
- programming, 14
- reading registers, 81
- register definitions, 83
- register types, 81
- registers, 83
- resetting, 82
- selecting channels, 14
- specifications, 73–74
- understanding, 41–46
- using, 31–40
  - with HP command module, 24
  - with HP mainframe, 24
- writing to registers, 82

## N

Numeric Command Parameters, 49

## O

\*OPC, 71

\*OPC?, 71

Opening

- channels, 33, 59
- multiple channels, 33
- order for multiple channels, 33

Operation Status Register, 46, 63

- bit value, 64
- setting bit 8, 64

Optional

- command parameters, 49
- commands, 16, 48

OUTPut Subsystem, 57

OUTPut#STATe, 57

OUTPut#STATe?, 57

## P

Parameters, 49

Pinout, 29

Port

- Event In, 41
  - scanning using, 45
- external trigger, 44–45
- Trig Out, 36, 44
  - enabling, 41, 57
  - query state, 57
  - scanning using, 45
  - shared by switchboxes, 57
- voltmeter complete, 45

Program Examples

- closing channels, 17
- measure voltage by scanning, 36
- resetting the switchbox, 17
- scan complete interrupt, 46
- scanning using event in port, 45
- scanning using trig out port, 45
- scanning with external devices, 44, 60–61

Programming the Multiplexer Module, 14

Protection Resistors, 13

## Q

Query

- error queue, 67
- open/closed channels, 33, 59–60
- scanning
  - cycles, 52
  - mode state, 62
  - states, 56
- trig out port, 57
- trigger sources, 70

## R

\*RCL, 71

Reading

- channel registers, 81
- device type registers, 81
- ID registers, 81
- registers, 81
- status/control registers, 81
- tree switch registers, 81

READIO, 79–80

Register-Based Programming, 77–83

- base address, 78–79
- computer configurations, 79
- DIAG#PEEK?, 79–80
- DIAG#POKE, 79–80
- embedded computers, 80
- external computers, 80
- IBASIC, 80
- register number, 80
- register offset, 80
- throughput speed, 79–80
- VXI#READ?, 79–80
- VXI#WRITE, 79–80

Registers

- addressing, 77–79
- base address, 78–79
- channel, 80
- channel register, 81–83

- control register, 81–83
- definitions, 83
- device type register, 81, 83
- ID register, 81, 83
- number, 80
- offset, 80
- operation status register, 46, 63–64
- reading, 81
- status register, 46, 63, 81–83
- tree switch register, 81–83
- Relay Life, 73–75
- Relay Replacement Strategy, 75
- Resetting the Module, 82
- Resistance Measurement, 34
- Resistors
  - location of, 13
  - purpose of, 12
- ROUTE Subsystem, 58–62
- ROUTE#CLOSE, 31, 33, 58
- ROUTE#CLOSE?, 31, 33, 59
- ROUTE#OPEN, 31, 33, 35, 59
- ROUTE#OPEN?, 33, 60
- ROUTE#SCAN, 31, 38, 60–61
- ROUTE#SCAN#MODE, 31, 38, 61
- ROUTE#SCAN#MODE?, 62
- ROUTE#SCAN#PORT, 31, 38, 62
- \*RST, 71–72
- RT Tree Switch, 12–13
  - closing, 39

## S

- Safety Warnings, 19
- \*SAV, 71
- Scan Complete Bit, 46
- Scanning
  - channels, 60
  - commands, 41–42
  - continuous cycles, 38, 55
  - cycle, 51, 56
    - continuous, 38, 55
    - multiple, 38
    - query, 52
  - query state, 56
  - range of channels, 36
  - requirements of a switchbox, 38
  - trigger sources, 41, 69–70
  - using
    - bus triggers, 70
    - event in port, 45
    - external triggers, 69
    - trig out port, 45

- with external instruments, 41, 44, 60–61
- Scanning Voltmeter
  - card numbers, 14–15
  - configuration, 14, 24
  - logical address, 24
  - selecting channels, 14
- Schematic, simplified, 13
- SCPI Commands, 47–49, 72
  - abbreviated, 48
  - ABORT, 50
  - ARM subsystem, 51–52
  - DISPlay subsystem, 53–54
  - format used, 16, 47
  - implied, 16, 48
  - INITiate subsystem, 55–56
  - linking, 49
  - optional, 16, 48
    - parameters, 49
  - OUTPut subsystem, 57
  - parameters, 49
  - programming with, 14
  - quick reference, 72
  - reference, 49–70, 72
  - ROUTE subsystem, 58–62
  - scanning, 42
  - STATus subsystem, 63–64
  - SYSTEM subsystem, 65–67
  - TRIGger subsystem, 68–70
- Select Code 8, 80
- Selecting
  - channels, 14
  - interrupt priority, 26
- Service Request (SRQ), HP-IB, 46
- Setting
  - card ID, 23
  - logical address switch, 23
  - scan complete bit, 46
- Signal Conditioning Components, adding, 27–28
- Specifications, 73–74
- Speed of Throughput, 79–80
- \*SRE, 46, 71
- \*SRE?, 71
- Static Electricity, 19
- Status Register, 46, 63
  - definition, 83
  - reading, 81
  - writing to, 82
- STATus Subsystem, 63–64
- STATus#OPERation#ENABLE, 46, 63
- STATus#OPERation#EVENT?, 46, 64
- \*STB?, 46, 71
- Strain Gages, 5 volt excitation, 27

Switchbox  
 card numbers, 14–15  
 configuration, 14, 25  
 connecting  
   channels to common, 32  
   to tree terminals, 34–35  
 continuous scanning, 55  
 logical address, 14–15, 25  
 measure thermocouple temperature, 39  
 multiple module, 15, 33  
 scanning  
   channels, 41, 60–61  
   commands, 41  
   range of channels, 36  
   requirements, 38  
 selecting channels, 14  
 single module, 14, 33

Switches  
 AT Tree, 11–13, 34–36, 38–39  
 AT2 Tree, 11, 13, 35, 38–39  
 BT Tree, 11–13, 34–35, 38  
 channel, 11  
   relay, 11  
 logical address, 23  
 RT Tree, 12–13, 39  
 tree, 11–13

SYSTEM Subsystem, 65–67  
 SYSTEM#CDEscription?, 65  
 SYSTEM#CPON, 66  
 SYSTEM#CTYPE?, 66  
 SYSTEM#ERRor?, 67

## T

Temperature Measurement, 39–40  
 Terminal Modules, 11  
   jumper, 12  
   wiring, 21  
     guidelines, 20

Thermocouple  
 compensation, 40  
 measuring temperature with, 39–40  
 wiring, 20

Throughput Speed, 79–80  
 Tree Switches, 11–12  
   AT, 11–13, 34–36, 38–39  
   AT2, 11, 13, 35, 38–39  
   BT, 11–13, 34–35, 38  
   register, 81–83  
   RT, 12–13, 39  
   terminals, 11

Tree Terminals, connecting, 34–35  
 \*TRG, 71–72  
 Trig Out Port, 36, 44  
   enabling, 41, 57  
   query state, 57  
   scanning using, 45  
   shared by switchboxes, 57  
 Trigger Sources, scanning, 41, 69–70  
 TRIGger Subsystem, 68–70  
 TRIGger#IMMediate, 68  
 TRIGger#SOURce, 41, 69  
 TRIGger#SOURce?, 70  
 \*TST?, 71–72

## U

Understanding the Multiplexer Modules, 41–46  
 Using  
   event in ports, 45  
   HP command module, 24–25  
   HP mainframe, 24–25  
   scan complete bit, 46  
   scanning trigger sources, 41  
   scanning voltmeter configuration, 24  
   switchbox configuration, 25  
   the relay multiplexer modules, 31–40  
   trig out ports, 45

## V

Verifying Logical Address Settings, 25  
 Voltage  
   maximum allowed, 19  
   measurement, 34  
     by scanning, 36  
   sense direct, 13  
   sense tree, 13  
   specifications, 73–74  
 Voltmeter Complete Port, 45  
 VXI Peripheral Interrupt Bus, 26  
 VXI#CONF#DLAD?, 25  
 VXI#READ?, 79–80  
 VXI#WRITE, 79–80

## W

\*WAI, 71  
 Warning, 19  
 Wiring  
   guidelines, 20  
   terminal modules, 20–21, 29  
 WRITEIO, 79–80  
 Writing

to registers, [82](#)

to status control registers, [82](#)

*Notes:*

---